



MINISTRY OF DEFENCE (PROCUREMENT EXECUTIVE)

AERONAUTICAL RESEARCH COUNCIL

CURRENT PAPERS

**Andover C. Mk. 1
Airfield Criteria Trials**

By

J. Howell

Engineering Division

A and AEE, Boscombe Down

LONDON: HER MAJESTY'S STATIONERY OFFICE

1972

Price £1 35 net

Andover C. Mk. 1

Airfield Criteria Trials

by

J. Howell,
Engineering Division,
A and A.E.E., Boscombe Down

ROYAL AIRCRAFT ESTABLISHMENT
BEDFORD.

SUMMARY

This report describes tests on various types and conditions of soil and surface profiles and concludes that the Andover C. Mk.1 can be operated without excessive damage from natural and semi-prepared surfaces subject to certain specified limitations. On smooth surfaces of adequate bearing strength, operation can proceed within the existing CA Release for paved surfaces. On rough surfaces, within the recommendations for profile and bearing strength, take-off and landing weights are restricted. Loose surface materials are acceptable subject to performance considerations, up to 6 in. in depth when dry or 3 in. when wet, provided that the sub-grade bearing strength at these depths is adequate.

Information is given to assist "in the field" assessment of surface suitability.

* Replaces A.R.C.31 190

List of Contents

	<u>Page</u>
1. Introduction	3
2. Description of Aircraft and Instrumentation	3
2.1 Aircraft	3
2.2 Tyre pressures	3
2.3 Instrumentation	3
3. Method of Test	5
3.1 Development of test methods	5
3.2 Provision of test facilities	5
3.3 Tests	7
4. Results of Tests	8
4.1 Working limits	8
4.2 Soil bearing strength records	8
4.3 Tests on concrete surfaces	8
4.4 Tests on grass surfaces	8
4.5 Tests on soft surfaces	10
4.6 Tests on rough surfaces (simulated)	11
4.7 Tests on undulated surfaces	12
4.8 Tests on ramps	13
4.9 Taxiing tests	15
4.10 Wing and fuselage bending moments	15
4.11 Surface profile assessment	15
5. Discussion	17
5.1 Bearing strength requirements	17
5.2 The effect of soft soils or loose surface material	17
5.3 Roughness criteria	19
5.4 Undercarriage fatigue spectrum	23
6. Conclusions	23
7. Recommendations	23
Acknowledgements	26
References	27

Appendix

Andover C. Mk. 1 Airfield criteria trials - Report on the use of a MEXE profilometer	47
---	----

Illustrations Figures 1 to 37

Detachable Abstract Cards

1. Introduction

1.1 To enable a clearance to be recommended for Andover C. Mk. 1 operation on natural and semi-prepared surfaces in accordance with the Standard of Preparation No. 51, para. 6, a series of trials was conducted between June, 1966 and October, 1967. Tests were carried out on a range of natural surfaces and on several prepared test facilities at A & AEE. Most of the take-off and landing tests were conducted in the Short take-off and landing (STOL) mode, as it was assumed that this would be the method used in off-runway operation.

1.2 This trial was preceded by a qualitative assessment of the Andover C. Mk. 1 on four typical semi-prepared airstrips in the Aden area (Ref.1).

1.3 A detailed analysis of the test results will be issued by HSA Ltd., giving resolved undercarriage reactions in various conditions and an undercarriage fatigue spectrum.

1.4 Records from the trials of fuselage and wing bending were collected for RAE Structures Dept., together with the corresponding terrain profiles to provide information for the establishment of undercarriage dynamic response characteristics.

1.5 Use was made during the trial of a prototype MEXE profilometer as an aid to the determination of the suitability of the terrain profile for use by Andover C. Mk. 1. Accurate orthodox surveys were also made of a number of the surfaces tested.

1.6 The behaviour of a Land Rover on rough ground was investigated as an aid to qualitative determination of relative surface roughness and the closure of the aircraft nose oleo was monitored for a similar purpose.

2. Description of Aircraft and Instrumentation

2.1 The aircraft was the third production Andover C. Mk. 1, Serial No. XS 596, and was representative of Service standard. It was designed as a tactical transport with STOL (Short Take-off and Landing) capabilities and was provided with main undercarriage units capable of absorbing a maximum rate of descent of 14.5 ft./sec. up to 38 000 lb. AUW. Maxaret wheel brakes were provided and the aircraft had 14 ft. 6 in. Rotol 4-bladed, constant speed propellers capable of feathering and reversing.

2.2 Tyre pressures specified for the trial were those quoted in AP 101 B 0301 according to aircraft weight.

2.3 The initial instrumentation fit was carried out by HSA Ltd., in accordance with their schedule ARI/3246/1 Issue 4. During the trial certain changes and re-distribution of instrumentation took place but the following is a general list of the parameters recorded.

2.3.1 Main undercarriage (see Fig. 1)

- Drag strut end load (Strain gauge No. 1)
- Wheel lever bending (" " No. 2 & 3)
- Liquid spring end load (Strain gauge No. 4)
- Main forging torsion (" " No. 5)
- Main forging side bending load (Strain gauge No. 6)
- Wheel lever angle (leg closure)

Brake/

Brake application
Local loads near wheel lever axle
Brake Maxaret pressures
Local loads at wheel lever fulcrum
Wheel rotation (P & S)

2.3.2 Nose undercarriage (see Fig. 2)

Drag strut end load (Strain gauge No. 7)
Nose leg side bending load (Strain gauge No. 8)
Nose leg end load (Strain gauge No. 10)
Torque link side bending load (Strain gauge No. 9)
Nose leg nitrogen pressure
Castoring and steering angle
Nosewheel steering jack fatigue monitor
(by hydraulic pressure exceedance)
Steering jack connecting rod load (Strain gauge No. 11)

2.3.3 Structure

Port and starboard wing bending was measured by strain gauges attached to the vertical flanges of stringers at the top and bottom centre chord of the torsion box. These were positioned at 20 ins. and 125 ins. outboard of Rib 0 (Bodyside), the outer ones being thus just outboard of the nacelle.

Fuselage bending was measured by strain gauges attached to the vertical flanges of the top and bottom stringers at station 36A in the rear fuselage.

2.3.4 Accelerations

Normal at c.g.
" at port undercarriage upper attachment
" at starboard undercarriage upper attachment
" at port engine nacelle
" at port wing tip
" at tail cone
Longitudinal at c.g.
Lateral at c.g.

2.3.5 General

A high speed camera was provided below the fuselage centre section capable of photographing all three undercarriages simultaneously. This camera provided a record of vertical velocity at touchdown, a light spot on the ground projected vertically downward from each undercarriage aiding calibration.

A camera was also used during operations on stony ground in an effort to detect any entry of debris into the starboard engine air intake.

Subsequent/

Subsequent to an undercarriage change, midway through the trials, a set of veeder counters was fitted to record main undercarriage side bending loads exceeding certain pre-determined levels, together with special "S/N" strain gauges on the main forging suspension lever lugs (Ref.2).

3. Method of Test

3.1 Development of test methods

Since the Service envisaged operations from a wide range of soil types and surface profiles it was considered that the trial should attempt to cover the major important variables and to determine their individual effects on the aircraft from the points of view of strength, contamination, damage, handling and performance. The latter two aspects are not the subject of this report and will be dealt with separately by Performance Division of A & AEE. The soil and surface variables which were considered from the engineering aspects were as follows.

- (a) Soil bearing strength.
- (b) Loose material, whether wet or dry, on a surface of adequate bearing strength.
- (c) Surface roughness. For simplicity this was considered from two aspects, the first being small scale roughness and recurrent irregularities, taken to be smaller in the line of motion than the tyre print. The second was large scale roughness, recurrent irregularities and undulated ground. It was assumed that in most typical cases of advanced landing strips, the worst irregularities - e.g., pot holes, rocks or odd mounds - would either be avoided by the layout plan or rectified by local labour to leave a contour which was rounded off to conform to a sensibly flat operating surface except for occasional undulations. The effect of these could be gauged from trials over sinusoidal representations of undulated ground, supplemented by tests with wooden ramps and cross checked by operations on rough grass airfields in Service use.
- (d) The effects of different soil types and surface conditions - e.g., wet, dry, sandy, muddy or stony.

3.2 Provision of test facilities (Fig. 3)

3.2.1 A smooth concrete runway was readily available for initial datum measurements as was a smooth natural grass strip (see Fig. 3 - Strip A, Porton Firs). Examination of local grass airfields and tactical landing strips produced a number giving an adequate variation in bearing strength, roughness, gradient and surface condition. Examples of these which were subsequently used were:- RAF Station Andover, RAF Station Abingdon and Upavon Gallops.

3.2.2 A 2000 ft. landing strip was prepared parallel to the main A & AEE runway by ploughing and harrowing (see Fig. 3, Strip D). Partial de-stoning was carried out and by taking advantage of varying weather conditions together with further harrowing or rolling as required it was possible to provide a range of surface conditions.

3.2.3 To provide more detailed information on small scale roughness, a matrix of holes was drilled at the centre of the length of runway 28/10 at A & AEE (see Fig. 3, Strip E). These holes could accommodate artificial bumps of various sizes either singly, recurrent or in a random pattern, with spacings in

multiples/

multiples of 5 yards up to 50 yards. The bumps provided were of either circular segmental section 2 in. high or of semi-circular section 3" high (see Fig. 4(a)).

3.2.4 Three undulated test strips of approximately sinusoidal form, were built parallel to runway 17/35 at A & AEE. The wave-lengths chosen for the strips, 50 ft. (C3), 75 ft. (C2) and 150 ft. (C1) were those estimated to cover a range which might prove critical for the Andover. The ratio of wave length (L) to total amplitude (λ) was based on a value $2/3$ of that recommended in JAC Paper 855, i.e., $\frac{L}{\lambda} = 150$. This figure was chosen for the initial tests as a result of earlier trials with Argosy and Beverley, where such a ratio had proved limiting. In these earlier trials a series of ten undulations had been used but there was insufficient evidence to show whether the undulation amplitude or their recurrent nature was the critical factor. It was arbitrarily decided to reduce the number of test undulations to three, as there was some limited evidence from a number of earlier surveys that this was the maximum number of natural recurrent similar undulations to be expected.

Thus the 150 ft. wave-length strip had 3 wave-lengths with a peak to trough height of 1 ft., the 75 ft. strip 3 wave-lengths with a peak to trough height of 6 in. and the 50 ft. strip 3 wave-lengths with a peak to trough height of 4 in.

Further investigation of recurrent large scale irregularities was facilitated by the manufacture of wooden ramps 3 in. and 6 in. high with a 1 in 50 leading slope which could be located in the hole matrix referred to in para. 3.2.3. The reasons for the choice of a 1 in 50 slope are discussed in para. 5.3.2.

3.2.5 Records of soil bearing strengths throughout the trial were obtained from the use of a MEXE (Military Engineering Experimental Establishment) pattern cone penetrometer (Fig.5). Readings obtained from the dial of the device, calibrated 0-300, could be approximately related to the California Bearing Ratio (Ref.5) when assessing cohesive soil strength in the relationship, Penetrometer/CBR, of 20:1. The penetrometer consists of a 30° hardened steel cone, having a base area of $1/5$ in.², attached point downward at the lower end of a spindle graduated in 3 in. divisions. The reaction of the soil against the cone, when it is inserted at a slow steady rate, deflects a spring at the upper end of the spindle which in turn operates a dial gauge. The instrument was invaluable in determining soil bearing strength in the field as the full CBR test is laborious and time consuming (Ref.5).

The procedure generally adopted for each test strip was, initially, to walk its length, testing at frequent intervals to establish whether or not the strip was consistent in its bearing strength. Subsequently, the strip was tested at three points spaced across the width of the strip approximately every 500 ft. lengthwise. At each test point, the penetrometer cone and spindle was pushed vertically into the soil with just sufficient force to maintain a slow, steady, penetration, the dial reading being noted as each 3 in. mark entered the ground surface.

3.2.6. Records of terrain profiles and relative roughness were obtained by accurate surveys of a number of the test sites. The results of these surveys will be found in detail in Ref.4 and examples are given in Fig.6 and 7 and Figs.3-6 of Appendix I. Experimental use was also made of a prototype MEXE profilometer (Appendix I).

During earlier trials, in connection with the CA Release of the Basset aircraft, use had been made of a Land Rover in an attempt to determine the relative roughness of grass airfields (Ref.6).

This/

This method was also employed during the Andover C. Mk. 1 trials to provide an approximate qualitative guide to the acceptability or otherwise, of a surface and was later extended to provide a guide to the existence of possibly critical undulations. The Land Rover was used both to give a "seat of the pants" indication and to produce records of peak vertical accelerations measured by a max./min. accelerometer (Fig.8).

3.3 Tests

In general, whatever the test surface, tests were commenced, at a low weight and central c.g. position, with slow taxiing and ground manoeuvring. This was followed by runs at increasing speeds, instrumentation records being obtained at each stage and the tests completed by take-offs and landings where required, with suitable changes in weight and c.g. position.

Except during operations on concrete, records were maintained of the soil bearing strength and where necessary, the surface profile. When the surface was soft, or stony, whether wet or dry, observations were made of the levels of damage and contamination and qualitative reports were made at each stage by the project pilot. This part of the investigation was aided by records from a cine camera, mounted so as to photograph the starboard propeller and engine air intake area.

During tests on the small scale simulated roughness, flight tests demonstrated the difficulty of landing on the bumps, which presented a small target to the approaching pilot. In order to achieve the most severe loading conditions for traversing bumps the aircraft approached them at a speed in excess of V_R and reverse thrust and brakes were applied just prior to the first bump.

Tests on the sinusoidal undulations were complemented by tests on wooden ramps with a 1 in 50 leading slope (see Fig.4b).

During the early stages of the trial a number of high side bending loads in the wheel lever attachment lugs of the main undercarriage forgings, were recorded (see Tables 10 and 12). Some yield of the forging material was indicated and the manufacturers advised that the undercarriage main forgings be replaced, owing to the severe effect that these high loads had had on the forging fatigue life. Following this replacement, instrumentation was installed to record main wheel rotation and, in subsequent tests the taxiing pattern for each sortie was identified on a sketch map and on the instrumentation records. The approximate radius of turn and ground speed could then be determined, from which a spectrum of undercarriage side loads during taxiing and turning was produced (see Fig.10).

The test conditions are detailed in the following tables:

Table 1	Concrete surfaces
Table 2	Grass surfaces
Table 3	Soft surfaces
Table 4	Artificial bumps
Table 5	Undulated surfaces
Table 6	Ramps

4. Results of Tests

4.1 Working limits

At the commencement of the trial, working limits for combined loading of the main and nose undercarriages were recommended by Messrs. Dowty Rotol Ltd. as a guide for day to day analysis of trials progress (Table 7). These arbitrary limits were considered safe estimations based on design calculations and any individual occasion on which a limit was exceeded, was then investigated further before the trial proceeded.

It soon became apparent that the instrumentation records presented information in a form which required considerable manipulation to obtain comparisons with the recommended maxima. As a result working limits were established for each strain gauged component based on the undercarriage loading used for strain gauge calibration (Table 8). As in the previous case the overshoot of any limitation was investigated to ascertain whether any of the undercarriage design cases had been exceeded.

4.2 Soil bearing strength records

The bearing strengths, in CBR %, recorded during the trial are given in the loading tables where appropriate.

4.3 Tests on concrete surfaces

The general level of maximum undercarriage component loads measured during the initial phase of the trial on concrete surfaces are summarised in Table 9 and refer to the tests covered in Table 1. There were however, certain isolated peak loads which, due to their apparent effect on the undercarriage main forging fatigue life and the circumstances of their occurrences, are tabled separately in Table 10.

4.4 Tests on grass surfaces

4.4.1 Instrumentation records

Table 11 lists a typical selection of the results recorded during operations off the various grass surfaces detailed in Table 2. The table is arranged to illustrate the trend of measured loads under deteriorating surface conditions. For each item a range of peak loads is given and in each column these peak loads are not necessarily coincident, i.e., the peak main undercarriage vertical load may occur at touchdown and the nose leg end load during the subsequent deceleration.

As in the case of the initial tests on concrete, detailed in para.4.2., certain excessive main undercarriage side loads were recorded at an early stage in the taxiing tests on grass. This had a serious effect on the main forging fatigue life, which resulted in the need to replace the forgings. The details of these high loads are given in Table 12.

Subsequent to the main undercarriage rebuild, a considerable amount of taxiing was monitored and the results are given in para.4.9.

During operations on rough surfaces a record of the nose oleo leg compression on each landing or taxi run was maintained for comparison with the peak end load results. This phase of the tests is summarised in Fig.11.

4.4.2 Qualitative results of grass operations

4.4.2 Qualitative results of grass operations

Operation from dry firm grass produced no unexpected results. When the surface profile was of a similar order to that of a concrete runway and the bearing strength was sufficiently high, the aircraft could be operated within the normal release for paved surfaces. There was little contamination of the aircraft other than the collection of grass clippings in the cabin supercharger air intake filters.

The aircraft was able to operate satisfactorily with a surface CBR of 3%, which was generally the case on dry grass. Where the CBR increased with depth, the amount of rutting was negligible. Occasional turf damage resulted from momentary locking of main wheels during braking. With increase in soil moisture content there was a tendency for the soil bearing strength to reduce to 1-2% CBR immediately beneath the turf mat, i.e., at about 1 in. in depth and in these cases some rutting, of the order of 1-1½ ins. occurred. A similar depression beneath the main wheels resulted when the aircraft was standing. There was a tendency in these conditions for the turf to peel back when the aircraft turned and attempts to carry out repeated operations on the same area would have led rapidly to degradation of the surface to the point where difficulty in manoeuvring would have become apparent (Figs.12 and 13).

Further increase in moisture content and consequent lowering of CBR near the surface, such as occurred at Upavon Gallops on 25th January, 1967 and 2nd February, 1967 and Porton Firs on 11th January, 1967, resulted in some difficulty in manoeuvring and disintegration of the soil surface in the wheel tracks. On these occasions, the soil surface layer ranged from semi-liquid mud (CBR → 0) to very soft fibrous material (CBR at 3 in. † 2%). Figs.14 and 15 illustrate the soil texture. In addition to the muddy surface layer, the sub-grade at 2 in. and below was frozen hard on the third occasion mentioned above.

Considerable aircraft contamination resulted from tests in these conditions (see Figs.16-25). All exposed forward and lower areas collected a heavy build-up of soil from which some of the moisture had been forcibly extracted on impact. The undercarriage wheel bays, door mechanism and hinges and flap tracks and hinges were heavily contaminated. There was considerable packing of soil between the wheels and in the brake units, which may have resulted in some sluggishness in the release of brakes during Maxaret operation. Several instances were observed of one or more wheels remaining stationary for several yards at a time, during a landing run. Similar instances observed during take-off may have been due to the packing of mud in the wheel providing sufficient rotational drag to cause the wheel to plane on the slippery surface. The feasibility of this kind of operation is discussed in para.5.2.

Damage occurred to the flaps and inner wing leading edges from the impact of loose wet soil and turf divots during take-off (Fig.2). There was evidence from mud splashes on propeller blades and engine air intake leading edges, of the ingress of mud to the engines (Fig.23). In three movements on the muddy ground the cabin supercharger air intake filters were choked with soil and grass (Fig.17).

Subsequent cine photography of the engine air intake area of the starboard engine produced no conclusive evidence of the entry of debris into the engine although a few instances were observed of debris being deflected by the propeller from points near the hub.

The results of the tests on grass, together with tests on artificial roughness and undulations, showed that the large scale surface irregularities which produced structural loads near the accepted limits, resulted in aircraft pitching which could be detected by the pilot. Details of this effect and general information on ground handling will be reported by Performance Division of A & AEE.

It/

It became apparent during traverses of rough ground and from the subsequent load analysis that the use of wheel brakes resulted in considerably higher nose leg end loads. This was of course due to the brake drag at the moment of wheel slip resulting in an accentuated nose-down pitching moment. From the limited number of tests carried out there is some evidence that the avoidance of the use of wheel brakes above normal taxiing speed when landing on rough ground, can reduce the nose leg end load by up to 40%.

4.5 Tests on soft surfaces

4.5.1. Instrumentation records

The loads recorded during operations on soft loose soil are summarised in Table 13. These illustrate the effect of soil variation on the loading. The effects of varying depths of soft soil on the aircraft performance and ground handling will be dealt with in a Performance Division report. Tests on the strip when softened to a depth of 6 in. were terminated at a weight of 40 000 lb. due to excessive rutting.

Note:- Table 13 gives the range of loads measured in a number of movements in each sortie. The peak loads measured for such items are not coincident, e.g., liquid spring and drag strut peak loads tended to occur at touchdown, side bending peaks during the subsequent taxiing and turning and nose leg end loads during the landing run when a particular obstruction was traversed.

4.5.2 Qualitative results of operation on soft surfaces

Throughout the tests on soft soil the CBR was maintained within fairly close limits as an aid to performance measurement. The values of CBR at the start of each sortie are given in Table 3, column 4 and Fig.27. During the tests with a nominal 3 in. softened layer there was a tendency for the trafficked surface to soften progressively at the higher aircraft weights, e.g., at 44 000 lb. the depth of softening had increased to 6-8 in. (CBR approximately 1%) after 3 take-offs and landings (6 passes). In the case of the tests with a 6 in. soft layer this process also occurred but to a greater extent leading to considerable rutting.

When the soil surface was soft to 3 in. the general order of rutting was 1-2 in. for the nose-wheel and $\frac{3}{4}$ -1 in. for the mainwheels, there being some filling of the ruts by loose soil behind the wheels. The soil tended to form 1-2 in. banks at either side of the wheel ruts (Fig.28). Where the aircraft was stationary the local ruts were of the order of 5 in. and 3 in. for the nose and mainwheels respectively. In the later stages of the tests, when the soft layer was increased to a nominal 6 in., heavy braking resulted in severe rutting, necessitating some digging to free the mainwheels in order to avoid the use of extreme power to move the aircraft. This might have resulted in the scouring of the propellers and undersurfaces by debris. The ruts caused were of the order of 1 ft. with soil banked to 3 in. at the sides of the ruts.

As described in para.3.3.3 the soil of the test strip contained a high proportion of flints of various sizes and this gave rise to a problem in relation to tyre, propeller and airframe damage. It was considered at one time that the tests might have to be abandoned, but by a process of stone-picking to remove the larger obstacles and frequent harrowing and ploughing to provide a fresh soil layer,

the/

the damage was kept to manageable proportions for test purposes. When the strip was dry the aircraft slipstream tended to strip the top-soil leaving the stones, with resulting increase in damage levels with repeated passes. There was also a tendency for the propellers to suck up debris if the aircraft was run at high power, stationary.

In the event, 10 nose wheel and 12 main wheel tyres were changed during a total of 60 movements (1 movement = 1 take-off and landing or 2 taxi runs). One series of tests was conducted when the strip had started to thaw following a period of severe frost. In this condition the upper 2 in. of the surface consisted of waterlogged soil resting on, and quite distinctly separate from, a hard frozen sub-grade (Fig.29). The purpose of the test was primarily to investigate ground handling in such conditions but a secondary effect was that the sharp stones embedded in the frozen sub-grade caused the most severe tyre damage experienced in the whole of this phase of the trial. One nose-wheel tyre was punctured such that it deflated slowly, the other was partially severed by a large radial cut, deflating instantly, and all the mainwheel tyres were cut to an extent necessitating replacement, in two normal speed taxi runs (See Figs.16 and 30).

Many minor abrasions occurred to the flaps and flap tabs and several punctures of the flap skin necessitated local repair. Minor abrasive damage was also suffered by the inner wing leading edges, nacelle panelling and inner wing and fuselage bottom skins. Many minor nicks occurred to the propeller blades and a number of more serious chips which were near the accepted repair and blending limits. These were, however, all blended as the tests proceeded, but the propellers were considered to have reached the presently accepted limit of repair at the end of the tests (see Fig.37).

A considerable amount of dust was disturbed by the slipstream and the passage of the aircraft during take-off and landing. Extreme care was taken when using reverse thrust and this was always cancelled when a forward movement of the dust cloud over the wing was observed. No engine trouble was experienced due to debris ingestion and inspection of the engines as far as was possible during the tests revealed no obvious erosion. Subsequent strip examination confirmed the serviceable condition of the engines at the end of the trial.

Contamination of the aircraft structure was not a major problem although small stones tended to lodge in the gaps between the undercarriage doors and nacelles. Dust built up around the flap tab hinges and flap tracks and some entered the gap at the forward edge of the tail loading ramp. It also penetrated the flexible seals of the under fuselage inspection panels, a fault previously experienced when operating off muddy ground.

4.6 Tests on rough surface (simulated discrete bumps)

In addition to and in conjunction with, the tests carried out on varying degrees of natural roughness, the effects of 2 in. and 3 in. rounded bumps, superimposed on an otherwise smooth surface were investigated (Figs.4a and 31).

4.6.1 Instrumentation records

The test results are summarised in Table 14.

4.6.2 Qualitative results of bump tests

At no time during these tests was any effect on the aircraft visible from the ground, the bumps appearing to be absorbed in tyre deflection. Pilots reported that the bumps could be heard rather than felt and the impact of the

wheels/

wheels on the bumps could be heard above the engine noise by an observer on the ground. It was considered that slightly larger bumps of rounded form might be acceptable but because a further increase in bump height to say, 4 in. would have corresponded approximately to the maximum permissible tyre deflection, it was judged that a 3 in. discrete bump would be a safe maximum.

4.7 Tests on undulated surfaces

4.7.1 Instrumentation records

Table 15a summarises the results obtained during tests on three 150 ft. undulations with a peak to trough height of 1 ft., Table 15b those appertaining to the three 75 ft. undulations, peak to trough height 6 in., and Table 15c the results of tests on the three 50 ft. undulations, peak to trough height 4 in. The peak loads measured in each test are quoted but are not coincident in all components.

4.7.2 Qualitative results of tests on undulations (see Figs.32 to 34) 150 ft. undulations

Initial tests were carried out at mid c.g. with the control column held forward to minimise the effect of possible pitching. Pitching did occur, however and increased with speed, there being a marked increase to violent pitching around 60 kts. At speeds approaching 60 kts. the aircraft became difficult to control both in pitch and direction and the nosewheel lifted for distances of 50 ft. at a time, sometimes striking the ground displaced from the fore and aft centre-line with resultant tyre scrubbing. As Table 15a shows, this was accompanied by very high nose leg end loads which resulted in one case in almost complete bottoming of the oleo leg and damage to the end load strain gauge bridge.

A series of take-offs was made over the undulations, the take-off run being started at various distances between 100 and 650 ft. from the first undulation. In all cases there was considerable pitching, the aircraft tending to be launched into the air from the crest of one or other of the undulations, depending on the starting point, at 8-10 kts. below V_R , sinking back to the ground either on or beyond the undulations. During this series of tests the control column was held back from the start of the take-off run but it was considered that this was not a good technique from the control point of view and in subsequent tests a neutral control column position was adopted with the pilot attempting to damp pitching as it occurred. The effect of this was to reduce the nose leg end load during traverses of the undulations, although moderate pitching still occurred between 35 and 50 kts. with a marked increase to violent pitching at speeds between 55 and 65 kts.

75 ft. undulations

The picture which emerged from these tests was generally similar to that of the previous paragraph except that the sudden increase in pitching occurred at about 40 kts. and was even more violent than before, to the extent that take-off tests could not be considered.

The result of changing from a forward control column position to an aft one was to considerably lessen the nose leg end load but to increase the pitching oscillation of the aircraft. Similarly the effect of moving the c.g. aft was to lessen the nose leg end load and of moving it forward to increase the load. The use of flap in the take-off position also appeared to accentuate pitching.

50 ft. undulations/

50 ft. undulations

No pitching was observed during any of the test runs over this size undulation. Very slight vertical motion was noticed at about 30 kts. and the highest main and nose undercarriage loads were also recorded at this speed. Higher speeds resulted in progressively lower peak component loads and take-offs were quite normal. The results of decelerations from high speeds demonstrated that no undue loads or abnormal motion would be expected during landings.

General

The tests described above on the three available sizes of undulations having demonstrated that certain limitations had been exceeded, it became necessary to carry out further tests in an effort to determine the acceptable large scale recurrent roughness envelope for the Andover. As the alteration of the existing undulations or the construction of new test sites was not practicable, further investigation of the effects of recurrent obstructions was pursued by the construction of wooden ramps which could be located at various positions on a smooth runway surface.

4.8 Tests on wooden ramps

4.8.1 Instrumentation records

Table 16a illustrates the peak undercarriage component loading when each undercarriage separately traversed 2 x 3 in., 1 in 50 leading slope ramps at various peak to peak spacings. The aircraft weight for all tests in this series was 42 000 lb., being the maximum STOL landing weight and the c.g. position was forward, giving the most severe condition for nose leg end loading, which had proved a criteria for rough ground operation.

Table 16b shows the component loading measured during various tests on 6 in., 1 in 50 leading slope ramps in various configurations.

4.8.2 Qualitative results of ramp tests (see Fig. 34)

(a) 3 in., 1 in 50 ramps

The speed band selected for each series of tests at each spacing of the ramps was that which would permit the frequency of energy inputs from the ramps to approximate to the pitching frequency of the aircraft.

Very small amounts of pitching were noted at all speeds and spacings. The ability of the aircraft to ride the ramps and to "iron out" their effect appeared to improve as speed increased, irrespective of the ramp spacing. This apparent effect is supported by the loads recorded and the general observed effect was similar to that on the 50 ft. ± 2 in. undulations.

At the higher speeds, from 30 ft. ramp spacing upwards, slight "nodding" of the engine nacelles and flexure of the wing tips was observed as the main wheel descended from the edge of the ramp. Examination of accelerometer and wing and fuselage bending records confirmed that this was not significant, (para.4.10 and Ref.7).

(b)/

(b) 6 in., 1 in 50 ramps

An initial series of tests between 10 and 40 kts. (Table 16b(i)), was carried out over 2 ramps spaced 45 ft. apart to investigate the behaviour of the aircraft when each undercarriage separately traversed the ramps. When the nosewheel was traversing the ramps at speeds up to 30 kts. it continued in the air for increasing distances, touching the ground before the second ramp. Above this speed the nosewheel left the crest of the first ramp and touched down again near the crest of the second. When the mainwheels were traversing the ramps, the descent of the mainwheel off a ramp caused the nosewheel to leave the ground at speeds over 10 kts. This series of tests gave indications of behaviour similar to that experienced on the 75 ft. and 150 ft. undulations and the two 6 in. ramps were then spaced at 75 ft. and widened to cover the full aircraft track.

In the subsequent test runs between 10-25 kts. a somewhat similar behaviour pattern was observed to that when traversing the 75 ft. undulations, except that the descent of the main-wheels from the ramp resulted in a pitch up of the nose. The nose wheel descended, compressing the oleo, just before traversing the second ramp, with the result that high nose leg end loads and oleo compressions were recorded (Table 16a(ii)).

Before proceeding to higher speeds with this ramp configuration, tests were made on a single 6 in. ramp with both leading and trailing slopes of 1 in 50, to determine the effect of the downward slope on the phenomenon noted in the previous paragraph. At 25 kts. there was a slight single pitching oscillation and at 35 kts. and above the mainwheel did not touch the downward or trailing slope. By the time the traverse speed had been increased in steps to 55 kts., there was no pitching and the mainwheel travelled in the air from the peak of the ramp for a distance of 40 ft., nearly twice the length of the ramp's downward slope.

The final ramp configuration tested was 2 x 6 in., 1 in 50 ramps having a leading slope only in the main wheel tracks and with 6 in. parallel sections added to the centre ramps, i.e., those in the nosewheel track.

The first test series, with the ramps spaced at 135 ft., attempted to simulate a similar configuration to the 150 ft. undulations with a halved peak to trough height. The results of these tests were quite innocuous, the nose-wheels describing a gentle arc after the crest of the first ramp, followed by the main wheels, at speeds of 40-50 kts., with no pitching apparent either to the observer or the pilot. At 60 kts. the ground observer noted a slight suggestion of a pitch up after the first ramp, which was not noticeable to the pilot. On the final run the aircraft reached V_R at the first ramp, was launched bodily, gently, into the air and could have continued a successful take-off had it been required. (Table 16b,(iv) shows correspondingly low loading.)

The final test series, with the ramps spaced 75 ft. apart, was intended to confirm the similarity in aircraft behaviour between similar ramps and undulations. This was borne out in the tests, the aircraft behaving very much as on the 75 ft. undulations. At 35-40 kts., the extremely violent pitching occurred, as on the undulations, with attendant high nose leg end loads and relatively high drag loads (Table 16b (iii) and 15b (viii)). With the speed increased to 40-45 kts. the pitching, whilst still considerable and unpleasant from the pilot's point of view, was less violent. It was further reduced at 45-50 kts. although one heavy compression of the nose leg occurred.

4.9 Taxying tests

Following the replacement of the undercarriage main forgings in October-December, 1966, subsequent upon the recording of very high side bending loads a large number of observations were made of taxying by six different pilots. 272 observations were plotted to give the ground manoeuvring envelope (Fig.10) and the taxying speed/turn radius spectrum (Fig.35). The maximum side bending moment measured during all the taxying and turning monitored, was 240 000 lb. in. compared with the recommended limit of 667 000 lb. in.

4.10 Wing and fuselage bending moments (Ref.7)

As a result of damage to an A & AEE Beverley front fuselage during taxying on undulated ground, measurement of wing and fuselage bending moments on the Andover, during the airfield criteria trials subsequent to the undercarriage change mentioned in the previous paragraph, was requested. Top and bottom stringers at two sections in each wing and aft of the rear spar in the fuselage were suitably strain gauged and the results obtained during a representative 36 take-offs and landings are given in Table 17 extracted from Ref.7.

The maximum wing and fuselage bending moments recorded, measured simultaneously during a STOL landing on the ploughed strip at 40 000 lb., Fwd c.g., with the surface softened to a depth of 6 in. were as follows.

Port wing inboard $+3.6 \times 10^6$ lb. in. (Permissible (50% ULT) $+7.6 \times 10^6$ lb. in.)

Port wing outboard -0.72×10^6 lb. in. (Permissible (50% ULT) -2.6×10^6 lb. in.)

Rear fuselage -5.7×10^6 lb. in. (Permissible (50% ULT) -7.3×10^6 lb. in.)

(The permitted 50% ultimate was an arbitrary limit proposed by H.S.A. Ltd.)

4.11 Surface profile assessment

During the course of the trials, as surfaces of varying roughness were investigated, it was necessary for two reasons to know the profile of the surface under consideration. The first and immediate requirement was to have the means of comparison of surface profile with test results. The second was to be able to recommend practical means of surface profile determination as an aid to "in service" evaluation of the suitability of any particular airfield, or the construction work necessary to make it so.

In connection with these aims, accurate centre line surveys were made of a number of the test facilities and these have been collated in a separate A & AEE Note, Ref.4.

The test sites surveyed were:-

Upavon Gallops
Porton Firs grass strip at A & AEE
RAF Andover, grass strip 30/12
The three undulated test strips at A & AEE
The soft earth strip at A & AEE

The use of a device, known as the MEXE Profilometer, was investigated as an aid to surface profile determination. The prototype of this device was made available to A & AEE by the Military Engineering Experimental Establishment, Christchurch, Hampshire. A discussion of its use, results and an appraisal is given in Appendix I to this report.

During earlier trials in connection with the operation of Basset aircraft from grass surface, measurements had been taken of peak vertical accelerations recorded when traversing various grass surfaces in a Land Rover. The procedure was also adopted during the Andover C. Mk. 1 trials, from which a qualitative assessment of the behaviour of the Land Rover was obtained on roughnesses found to be near limiting as a result of qualitative impressions and instrumentation records obtained from aircraft tests.

Generally speaking a surface which produced unpleasant pitching of the aircraft and nose-leg end loads approaching the limit load, could not be traversed in a Land Rover at speeds in excess of 30 mph with the vehicle under complete control. At higher speeds the driver and any passengers were thrown about violently with a risk of minor head injuries. Regularly recurring undulations, such as the 75 ft. test site at A & AEE, could be easily detected at 35 mph by the onset of fairly violent vertical motion. Undulations, having a peak to trough height of one foot caused the vehicle rear wheels to leave the ground at the undulation peaks. This was also the case when traversing a single 6 in. bump with 1 in 50 leading and trailing slopes, 35 mph being the maximum safe speed. Longer wave-lengths around 150 ft. did not produce the same violent vertical motion, but if the wave-length/peak to trough height ratio was less than 150 the change in longitudinal slope of the vehicle would become very apparent at 35 mph. The vehicle used for the tests did not permit higher speeds but the impression was gained on the 150 ft. undulations, that 40 mph would have been the safe limit.

A variety of Land Rovers were used during the trials, including long and short wheel base models in new and worn condition. Little difference could be felt subjectively in their behaviour on the examples of rough ground surveyed. The envelope of accelerations recorded by an accelerometer Type KB482/01, rigidly mounted between the front seats of the Land Rover, is given in Fig.8.

In addition to the foregoing surveys and "seat of the pants" methods of roughness determination, all the test sites were given a careful visual examination and it was found possible to detect bumps and declivities which might be limiting, provided the vegetation cover was not thick enough to mask them. A rough idea of the vertical profile could then be gained by the use of pegs and string. It was also noted that, if an inspection could be made late in the day when the sun was low and the position of the sun with respect to the strip centre-line was suitable, shadows would assist in pinpointing surface irregularities. This method could be extended with advantage, at night, by using a powerful light close to the ground and marking the centres of deep shadows for closer inspection.

5. Discussion/

5. Discussion

5.1 Bearing strength requirements

The measurements taken during the trials clearly show that, on a soil having the characteristic of bearing strength increasing with depth, the minimum requirement for a satisfactory operation of Andover C. Mk. 1 is a surface CBR of 3%. In this condition rutting in the line of straight motion rarely exceeded 1 in. On a surface of this strength however, more severe rutting occurs when wheels momentarily lock, or during turns if the turning circle is restricted. This is likely to be the case when the aircraft is required to operate from a strip cleared in jungle or dense undergrowth or where a minimum amount of time and labour has to be expended in clearing rocks and other obstructions.

An important factor in the ability of a surface to withstand aircraft manoeuvring is the shear strength of the soil near the surface. Whilst no measurements of shear strength were made, it was obvious from observations that the shear strength of a soil of given bearing strength was considerably higher when there was a strong turf or other similar root structure, than when the soil was bare. Thus, on dry grass with a surface CBR of 6%, no rutting occurred either during landing, taxiing or manoeuvring and the proposed requirement of 6% for 30 movements, quoted in the MOD Forward Airfield Criteria Handbook (Ref.8), was considered to be valid. On the other hand quite severe rutting at turning points resulted from operation with approximately the same CBR on bare soil, in the experience of Middle East Command. It would appear, therefore, that the part of an airstrip with no surface root structure, where landing and straight taxiing occurs, may have a surface CBR as low as 3% but to enable fairly continuous use with a minimum of maintenance it should preferably have a surface CBR of 6% or more. The turning areas should be capable of stabilisation to a higher CBR, either by compaction of existing soil, the importation of a compactable material, or the chemical treatment of the soil. Evidence from trials on the A & AEE ploughed strip showed that although rutting occurred in the soft upper layers of the soil, the bearing layer at a depth of 3-6 in. at the ends of the strip did not degrade appreciably during repeated manoeuvring when the CBR was 10% or more. The present trials therefore tend to support the HQMEC arbitrary estimate of 12-16% as the requirement for a bare earth strip where semi-continuous operation is necessary and soil stabilisation is not possible.

The task of assessing a surface from the strength aspect would be greatly facilitated by the development of a soil shear test method capable of use in the field.

5.2 The effect of soft soils or loose surface material

The trials on the A & AEE ploughed strip in various weather conditions and on the tactical airstrip at Upavon Gallops demonstrated that the aircraft could operate satisfactorily up to its normal landing weight (47 600 lb.) in a 3 in. layer of soft loose non-bearing material on a suitably strong sub-grade. Similarly at a weight of 40 000 lb. satisfactory operation was carried out when the layer of soft soil on the hard sub-grade was increased to 6 in. Trials were terminated at 40 000 lb. at this depth owing to the apparent degradation of take-off performance and the limited strip length available. At both depths at the maximum weights quoted there was a tendency for the main and nose undercarriage end loads and drag loads to become high although not excessively so (Table 13 (v), (vi)). On the basis of these rather limited tests, it is considered that a practical limit had been reached in both cases.

A layer of soft muddy soil up to 3 in. in depth produced difficulties in ground manoeuvring, the aircraft easily developing a skid if the speed in a turn was too high. The difficulty in maintaining a straight course was accentuated by rougher ground where the muddy top-soil was interspersed by tussocks of rough grass and fibrous soil. These conditions did not produce any excessive undercarriage component loading and take-off and landing were without incident except for the contamination of the aircraft. On the occasion of these tests ground conditions were such that a multi-wheel drive fire vehicle had some difficulty in manoeuvring and had to be used to tow a fuel tanker into position. Generally speaking, it was found that, if it were possible to manoeuvre the aircraft on the ground, it was possible to carry out take-off and landing.

Contamination of the aircraft external surfaces was severe in these wet muddy conditions and there is little doubt that some particles of soil and turf were ingested by the engines. No apparent ill effects resulted.

The possibility of flap tab and leading edge buckling due to strikes by loose divots and the general contamination of the aircraft's external surfaces and all orifices, makes this type of operation one which should be approached with extreme caution in the light of operational necessity. There was some evidence that damage to the undercarriage door mechanism might have resulted from undercarriage retraction, due to the build up of mud in the hinge gaps, although it is likely that most of this would break away when dry, after some minutes of flight. The adhesive properties of the mud would depend upon the soil type and this could only be determined by trial and error in the conditions prevailing at the time of any such operation. After-flight inspection of all gaps and orifices would be essential, and this would include inspection of the under floor space for mud ingress through bottom hatch seals, the dump valve on the fuselage under surface and cabin supercharger air intake filter. The availability of equipment for hosing the aircraft down would be essential.

In dry conditions, when the surface layer is loose sand and dust, the major problem is caused by the danger of ingestion of abrasive debris by the engines. This can be minimised by care in the use of reverse thrust, which must be cancelled at the first signs of any dust cloud moving forward of the wing. Contamination in these conditions concerns mainly small gaps, such as that between the ramp and rear fuselage and resulted during the trials in some micro switch faults in the ramp and rear fuselage and resulted during the trials in some micro switch faults in the ramp and door indication system. Other areas affected include all exposed lever bearing pivots moist with lubrication e.g., flap tab levers, undercarriage door mechanism, flap tracks.

When the soil surface contains an admixture of loose stones the problem becomes one of minor airframe and propeller damage and, if the stones are sharp edged, tyre damage. The evidence of the trials is that the propellers and airframe surface structure can withstand considerable amounts of such damage but conditions leading to it should be avoided if at all possible. Minor airframe abrasions are fairly readily repairable but the blending and repair of propeller damage is laborious. The propeller de-icing leading edge boots are also easily damaged by sharp stones and it is considered that the development of easily replaceable abrasion resistant blade sheaths would be worthwhile. Part of the airframe would also benefit from readily replaceable protection as follows:-

- (a) The fuselage bottom skin adjacent to the wing centre section to be protected by a glass reinforced plastic layer.
- (b) The centre section lower skin between the fuselage and nacelles and the leading edges to be protected by a glass reinforced plastic layer.

(c)/

- (c) The inboard wing flap and the flap tabs outboard of the nacelle to be similarly protected.
- (d) The lower anti-collision light protection to be improved by strengthening the wire mesh guard and increasing its size so as to provide additional clearance between it and the lamp glass.

To sum up, an airstrip with a surface containing loose stones, should only be used in extreme necessity, damage levels being carefully monitored, unless stabilisation of the surface can be carried out.

5.3 Roughness criteria

5.3.1 Small scale roughness

Based on the arbitrary definition that small scale roughness is that which is smaller than the tyre print in area, the Andover trials demonstrated that the aircraft could operate on ground having a random profile of 3" maximum height bumps, e.g., embedded stones, small depressions, small vegetation roots or abrupt and local changes in surface level (see Figs.9 and 31). Bumps of this nature are most unlikely to occur naturally in a regularly recurrent pattern, but a remote possibility remains that such a pattern might result from the use of land previously cultivated or artificially drained. If this were the case it should be noted that the fundamental bending frequency of the wing lies between 2.5 and 3.5 Hz (depending on the fuel state), so that taxiing between 22-31 kts. over regularly recurring bumps, 15 ft. apart, could excite this frequency and produce oscillations of large amplitude. For the same spacing of obstructions, 40 kts. would correspond to the wing torsional mode, 4.5 Hz. This could produce large amplitude "engine nodding". A speed of 62 kts. would result in energy inputs to the nose-wheel which could excite the fuselage bending mode at 7 Hz. Doubling the spacing of the obstruction would, of course, double the critical speeds. Localised obstructions 3 in. high if regularly recurring and more than two in number should not, therefore, be less than 50 ft. apart (an assumption supported to some extent by the tests on 50 ft. \pm 2 in. undulation, and on 3 in., 1 in 50 ramps at 15 and 30 ft. spacing).

The energy input from bumps less than 3 in. high was almost completely absorbed in the main and nose tyre deflection and is not considered to be of importance from the point of view of structural excitation.

5.3.2 Large scale roughness

5.3.2.1 Airfield roughness as examined

Runway 30/12 at RAF Station Andover produced a number of bumps of various sizes, one in particular giving high nose leg end loads (Fig.6). It will be seen that this was an irregular bump, 9 in. high from the bottom of an initial depression with a leading slope of 1 in 33 followed by several humps and a 6 in. deep ditch with slopes approximating 1 in 15. Other examples of typical natural bumps, measured during the trials, are shown on Figs.6 and 7.

5.3.2.2 Roughness simulation by wedges

When, following the initial series of tests on sinusoidal undulations, it became necessary to devise possible methods of producing different wave-lengths and peak to trough heights, consideration was given to reproducing the effects of undulations by the production of timber ramps. The side elevation area of a sinusoidal undulation was equated to that of a wedge shaped ramp with a flat trough

and/

and peak, for a given wavelength (L) and peak to trough height (λ), using the ratio $\left(\frac{L}{\lambda} = 150\right)$ of the existing undulated test sites. It was assumed that the total energy input to a wheel traversing the ramp of undulation was proportional to the cross sectional area. This exercise also gave a ramp slope of approximately 1 in 50.

Timber ramps having a leading slope of 1 in 50 and heights of 3 in. and 6 in. were then prepared and tests on them carried out coincidentally with tests on rough natural terrain, from which a roughness spectrum acceptable to the aircraft was defined. It became apparent early in the ramp tests that the main and nose wheels travelled through the air after leaving the ramps, except at very low speeds (< 20 kts.), and it was considered that a trailing slope on the ramps was not necessary for test purposes.

Ramp tests results showed that 3 in. bumps with a 1 in 50 slope could be traversed at 42 000 lb. AUW singly or at any bump spacing from the minimum of 25 ft. upwards. As in the case of small scale roughness, it is considered unlikely that such bumps will occur naturally at regular intervals but the possibility exists that previously cultivated ground could provide such a profile.

Natural bumps, of the order of those described above the Fig.6, were considered to be marginally too severe for continuous aircraft operation, but tests on a 6 in., 1 in 50 ramp proved this to be an acceptable maximum as an isolated obstruction. It was, however, likely to produce unacceptable pitching and high undercarriage loads if followed by a second or third such ramp with peak to peak spacing within the range of wave-lengths tested as undulations.

5.3.2.3 Simulation of undulating roughness

Undulations, of approximately sinusoidal form, could be accepted up to 42 000 lb. AUW at a wavelength of 50 ft., with a peak to trough height of 4 in., throughout the c.g. range. The effect of differing control column positions, during taxiing, on the undercarriage loading was insignificant.

At a wavelength of 150 ft., peak to trough height 1 ft., it was just possible to carry out take-offs, although these were only considered acceptable for trials purposes due to the lack of control in pitch. The pitching was also a severe problem at high taxiing speeds (50-60 kts.) (Fig.33). Structural and undercarriage component loads were within limits up to 42 000 lb., throughout the c.g. range, provided that the control column was maintained in a neutral to aft position throughout the taxi run, whether accelerating or decelerating. The nose leg end loads became excessively high when accelerating through 50-60 kts. if the control column was held forward in an attempt to reduce pitching. Undulations of this wavelength and height were thus considered to be marginally unacceptable, especially bearing in mind the necessity for a CA Release for off-runway operations to be applicable for both day and night use in line with the existing STOL release.

The third of the undulated test sites, having a wavelength and peak to trough height of 75 ft., and 6 in. respectively, gave totally unacceptable results, the pitching at medium speeds being so violent as to prevent adequate control, a state of affairs made worse by an aft control column position which was necessary to avoid unduly high nose gear loads. This was also the case with the 6 in., 1 in 50 ramps when spaced at 75 ft., but not when the spacing was increased to 135 ft., as near as the test facility would permit to the 150 ft. undulations (see Figs.32 and 34).

The/

The reasons for the critical nature of recurrent irregularities of sinusoidal, smoothly rounded or straight slope form appear to be twofold:

- (a) Amplitude or peak to trough height, the energy input to a traversing wheel being proportional to the side elevation area of the obstruction. This in turn is proportional to the height of the obstruction, for a given wavelength.
- (b) The frequency of the inputs of energy to the aircraft from the recurrent irregularities, in that, if the wavelength is such as to produce excitation of the fundamental pitching frequency of the aircraft in the critical speed band just below full control effectiveness, operation may be unacceptable due to pitching. This may also result in a loss of directional control in a cross wind.

Thus, with respect to (a) above, the 150 ft. undulations were marginally unacceptable with a peak to trough height of 1 ft. There was no opportunity to corroborate this with the wooden ramp simulation, tests with ramps of only 6 in. rise pitched at 135 ft. gave rise to no problems.

In the case of (b) violent pitching occurred on the 75 ft. undulations and the 75 ft., 6 in. ramps around 40-45 kts. and on the 150 ft. undulations at 60-70 kts. The fundamental pitching frequency of the aircraft was given as 0.7 to 0.9 Hz and 40 kts. on 75 ft. wavelength gives:

$$\frac{63}{75} = 0.84 \text{ Hz} \quad (40 \text{ kts.} = 63 \text{ ft./sec.})$$

65 kts. on 150 ft. wavelength gives:-

$$\frac{110}{150} = 0.74 \text{ Hz} \quad (65 \text{ kts.} = 110 \text{ ft./sec.})$$

During operations on runway 30/12 at RAF Andover a series of 3 rounded undulations with an approximate wavelength of 250 ft. and approximate peak to trough height of 15 in., were regularly traversed with no ill effect, suggesting that at this increased wavelength, ground speeds considerably higher than the Andover C. Mk. 1 operating range or a greater peak to trough height would be necessary to induce severe pitching.

When considering undulations of the order of 300 ft. wavelength or over the aircraft would only traverse one full undulation during the time its speed was high enough to make pitching possibly unacceptable, irrespective of its starting point with respect to an undulation peak or trough. A simple extrapolation of the roughness envelope was considered valid in this case giving a peak to trough height of 2 ft. (Fig.36)

5.3.2.4 Comments on roughness criteria for Service use

Having made STOL tests over both real and synthetic large scale roughness features (paras.4.6., 4.7., 4.8.) the results were examined as the trials progressed to see whether any simple definitions of limiting profile features could be given to assist the operator in assessing a rough airstrip.

The/

The definitions proposed are embodied in Recommendations at 7.2.9. As these definitions were prepared against some profiles which were synthetic and based on a known flat bed, it is expected that their use, in a fully generalised case with a completely random profile may present difficulties and discussion will be needed in applying the criteria.

For the Andover at a maximum landing weight for a STOL operation of 42 000 lb., the take-off ground roll distance is approximately 900 ft. The landing strip which needs to be defined and critically examined for profile features will therefore be approximately 900 ft. into wind. The width will depend on the predictability of wind direction and the importance attached to freedom from wind limitation, but it could be 60 ft. for initial operation.

Such an area of strip is assumed to be small enough to be found by selection, so that subsequent search of it will reveal little or no obvious profile irregularities along any potential wheel track. Any which do exist, such as ditches, ruts, depressions or mounds should be filled or flattened to leave no rise or fall or change in slope greater than 3" in any length of 12' 6".

These criteria appear to be more severe than were found acceptable on the grass airfield trials but nevertheless are postulated if a simple guide is required to define a satisfactory profile for initial operations.

Closer scrutiny of successive lengths each of 12' 6" may still reveal either the odd mound, or an undulation feature and these need to be assessed against the recommendations of para.7.2.9.

5.3.3 Gradients

Longitudinal gradients of ± 2.5 and $\pm 3.0\%$ were experienced during the present series of trials, on grass surfaces wet and dry. Similar gradients were experienced during the earlier trials in the Aden area (Ref.1).

The maximum lateral gradient experienced was of the order of 2%.

5.3.4 Determination of roughness

In order that the recommended roughness spectrum may be of practical use to the operator it is necessary that, in assessing the suitability of a landing strip, he has some easy method of determining the surface profile.

The estimation of a longitudinal or lateral profile is probably straightforward, needing no further discussion and the use of a theodolite and graduated pole will give a very accurate picture of profile and gradient. This method is laborious and may well not be available to the operator in the field.

Rough and ready methods used during the trials were:-

- (a) Close visual inspection.
- (b) Closer examination of suspect areas with pegs and string.
- (c) Qualitative assessment with Land Rover. This can be improved, in so far as assessing the worst bump on the strip, by the addition of an accelerometer.

(a)/

- (d) Qualitative assessment by the project pilot during taxiing at various speeds, assisted by observers on the ground who noted particular surface areas affecting pitching and also maintained a record of nose undercarriage oleo leg closure.
- (e) The oleo leg closure measurements referred to in (d) were compared with the end load figures recorded. These are summarised in Fig.11, where it will be noted that there is considerable scatter in the results. This is attributed to the recorded end load for a particular closure, being related to the rate of application of the load, which was a variable.

An additional method of profile determination examined during the trial, was the mechanical device known as the MEXE Profilometer (Appendix I). This, or some similar apparatus, if perfected, would certainly enable relative roughness to be easily determined and could possibly result in a fairly accurate quantitative determination.

5.4 Undercarriage fatigue spectrum

Results of the first stage of the trials, up to October, 1966 when it became necessary to replace the undercarriage main forgings, indicated little difference in fatigue counts between sorties operated from smooth grass and concrete. More fatigue damage was expected to be incurred during sorties from rough surfaces (Ref.10).

Subsequent analysis of fatigue life consumption is being carried out by HSA Ltd. Their work was aided to some extent, by special "S/N" fatigue strain gauges mounted on the wheel lever attachment lugs and by a counting device to record the number of times certain strain levels were exceeded.

6. Conclusions

6.1 The Andover C. Mk. 1 can be operated on natural and semi-prepared surfaces provided that the recommendations of para.7 are met.

6.1.1 Normal taxiing and manoeuvring on any of the surfaces or profiles acceptable to the aircraft is not likely to cause any undue side loading of the main undercarriage.

7. Recommendations

7.1 The Andover C. Mk. 1 can be operated on smooth unpaved surfaces of adequate bearing strength within the limitations of the CA release for paved surfaces.

7.2 The Andover C. Mk. 1 can be operated on natural and semi-prepared surfaces subject to the following detailed recommendations:-

7.2.1 The minimum bearing strength for a single operation must not be less than 3% CBR at the soil surface increasing to 4% at the 3 in. depth and 6% at 6 in. These figures refer to a maximum weight of 45 000 lb.

7.2.2 The load supporting surface CBR for extended operation must not be less than 7-9%

7.2.3/

7.2.3 The load supporting CBR in turning areas must not be less than 7-9% where the surface soil has a high shear strength due to turf cover or other similar root structure, or where soil stabilisation is possible.

7.2.4 In the absence of soil stabilisation, in order to minimise airfield maintenance, a CBR of 12-16% in turning areas is recommended.

7.2.5 A layer of loose dry sand, fine gravel or cohesive soil on the load bearing surface should not exceed 6 in.

7.2.6 The depth of soft wet soil or mud on a surface of adequate bearing strength must not exceed 3 in.

7.2.7 The maximum operating weights on rough or soft surfaces should not generally exceed 45 000 lb. take-off weight and 42 000 lb. landing weight. These recommended weights are also subject to any further provisions of Performance Division, A & AEE.

7.2.8 The maximum height of recurrent localised obstructions or discrete bumps, less than the tyre print in area, shall be 3 in. If these bumps (stones, brickbats, small roots etc.) are randomly distributed on an otherwise smooth surface the landing weight may be increased to 45 000 lb. using the recommended handling procedures for weights over 42 000 lb.

7.2.9 The following surface profile envelope must not be exceeded (see Fig.36).

- (a) Wedge shaped bumps not more than 3 in. high with a leading slope not greater than 1 in 50 and not recurring at less than 25 ft. intervals.
- (b) Smooth contoured or sinusoidal undulations from 25-100 ft. wavelength and having a maximum peak to trough height of 3 in.
- (c) Similar undulations from 100-150 ft. wavelength and having a peak to trough height rising linearly from 3 in. at 100 ft. to 6 in. at 150 ft.
- (d) Wedge shaped bumps not more than 6 in. high with a leading slope not greater than 1 in 50 and not recurring at less than 150 ft. intervals.
- (e) Smooth contoured or sinusoidal undulations from 150-200 ft. wavelength, having a peak to trough height rising linearly from 6-9 in.
- (f) Similar undulations upwards from 200 ft. wavelength, having a peak to trough height rising linearly from 9 in. at 200 ft. to 24 in. at 300 ft.

7.3 An airfield surface proposed for use by Andover C. Mk. 1 should be given a careful visual inspection to establish a general picture of the profile.

7.4 Some or all of the following methods should be considered as an aid to surface profile assessment.

- (a) Pegs and string.
- (b) Qualitative survey by Land Rover
- (c) Land Rover survey assisted by accelerometer readings (see Fig.8).

(d)/

- (d) Orthodox surveying.
- (e) Observation of the behaviour of the aircraft during taxiing.
- (f) The use of Fig.11 as a guide to limiting nose leg closure.

7.5 An airfield surface containing loose stones should be avoided if at all possible. Should operational necessity dictate the use of such an airstrip, tyre damage may be reduced by grading the surface and removing stones larger than 1 in. or by soil stabilisation. Prolonged static running at high power settings must be avoided to prevent stones being sucked into the vortex created below the propeller disc.

7.6 On dusty surfaces the use of reverse thrust must not be prolonged so as to cause debris ingestion by the engines, when the dust cloud moves forward of the wing.

7.7 The use of wheel brakes should be avoided above normal taxiing speeds when landing on rough ground to reduce nose gear loads.

7.8 When the aircraft is operating on dusty, muddy or stony ground or where the vegetation cover is disturbed by the passage of the aircraft, before and after flight servicing should pay particular attention to the inspection of the aircraft for damage and contamination. The cabin supercharger filter in particular, will require very frequent cleaning.

7.9 The MEXE pattern cone penetrometer should be employed for soil strength determination.

7.10 A protective cowl is recommended for the pressurisation dump valve orifice beneath the fuselage.

7.11 The glass reinforced plastic skin on the flap tabs should be extended outboard by a further 12-18 in. depending upon the location of suitable anchorage points.

7.12 The electrical terminal blocks at the near side of the main undercarriage bay should be protected by a waterproof cover.

7.13 A manufacturer's inspection and report is recommended for:-

- (a) The airframe and undercarriage of XS 596
- (b) The Dart engines
- (c) The Dowty Rotol propellers (with a view to more detailed information on repair limits).
- (d) The aircraft DC generators and alternators.

7.14 It is recommended that the MEXE profilometer be developed as an aid to rapid surface profile evaluation.

7.15 The development of a soil shear test method for use in the field is recommended.

Acknowledgements/

Acknowledgements

The assistance rendered by the following during the course of the trial is gratefully acknowledged.

Officer Commanding and Staff, RAF Andover

Southern Area Control HQ, Bulford, (MOD(Army))

Director and Staff of the Military Engineering Experimental
Establishment (MOD)

References/

References

<u>No.</u>	<u>Author(s)</u>	<u>Title, etc.</u>
1	L. O. Sturgess, Sqn. Ldr. Turner, D. Garrett and G. Marks	Unpublished MOD/DE report.
2	H.S.A. Ltd., Woodford, Cheshire.	Report No. Electronics/313.
3	Micro Measurements Inc. 38905 Chase Road, Romulus, Michigan, USA	Applications manual, the s/n fatigue life gauge.
4	J. E. Burt	Airfield criteria and pre-fabricated surfacing trials, terrain surveys. A & AEE Note No. 3026.
5	A & AEE	Handbook of test methods, Vol. 3, Instruction No. 21.
6	A & AEE	Engineering test note No. 484 Basset CC Mk 1 XS 743. Investigation into propeller ground clearance.
7	H.S.A. Ltd., Woodford, Cheshire.	Report No. ARD/F/780/76.
8	MOD(Army)	Forward airfield criteria handbook.
9	H.S.A. Ltd., Woodford, Cheshire.	Report No. ARD/F/780/318.

Table 1/

Table 1

Tests on Concrete Surfaces

Initial Take-off Weight lb.	CG Position	Object of Test	Date
48 000	Mid.	2 take-offs and landings (Normal mode)	7.6.66
50 000	Fwd.	6 take-offs and landings (Normal mode)	23.6.66
47 600	Fwd.	3 take-offs and landings (Normal mode)	27.6.66
47 600	Fwd.	3 take-offs and landings (Normal mode)	28.6.66
43 000	Mid.	7 take-offs and landings (STOL mode)	14.7.66
37 000	Fwd.	4 take-offs and landings (STOL mode)	23.9.66
41 000	Fwd.	Taxying over known radius turns plus 1 take-off and landing (STOL)	11.1.67
40 000	Fwd.	Measured accel./stops prior to aluminium mat trials	19.6.67

Note.- The appropriate instrumentation was operated during taxying in this and subsequent operation on concrete and prior to other tests, e.g. grass operation.

Table 2
Tests on Grass

Initial Weight	CG Posn.	Surface Condition	Test	Date
43 000	Mid	Smooth dry grass (Porton Firs)	3 slow taxi runs (20 kts.) with turns	14.7.66
43 000	Mid	Smooth wet grass (a) after rain (b) during rain	3 slow taxi runs (20 kts.) with turns	15.7.66
43 500	Mid	Smooth dry grass	3 TO and land (normal mode)	18.7.66
43 500	Mid	Smooth dry grass	6 TO and land (STOL mode)	20.9.66
37 000	Fwd.	Smooth wet grass	4 TO and land (STOL)	23.9.66
37 200	Fwd.	Smooth dry grass (Andover 25)	3 TO and land (STOL)	23.9.66
37 000	Fwd.	Medium rough grass (Andover 28)	1 slow taxi and ground manoeuvring. 2 TO and land (STOL)	23.9.66
36 000	Fwd.	Rough dry grass (Andover 30)	1 taxi 21.5 kts.	23.9.66
41 000	Fwd.	Medium rough dry grass (Andover)	4 TO and land (STOL)	27.9.66
40 000	Fwd.	Rough dry grass (Andover 30)	2 taxi runs 40 kts.	27.9.66
41 000	Fwd.	Medium rough wet grass (Andover)	6 TO and land (STOL)	4.10.66
41 000	Fwd.	Smooth grass. 1-2 in. saturated layer on frozen sub-grade	Slow taxiing, manoeuvring and braking	11.1.67
40 000	Fwd.	Medium rough grass (Upavon) Waterlogged sparse turf (semi-liquid to moist) on hard chalk	1 TO and land, taxiing and development of ground handling techniques	25.1.67
42 000	Fwd.	As above	2 TO and land plus taxiing as above	2.2.67
42 000	Fwd.	Rough grass (Abingdon)	Measured taxi runs plus 1 TO	24.2.67
42 000	Fwd.	Rough grass (Andover 30)	3 TO and land (STOL)	3.3.67
42 000	Aft	As above, moist grass	4 TO and land (STOL with varying rotation technique)	6.3.67
45 000	Aft	Medium rough grass (Andover 28)	2 TO and land (Normal)	20.3.67
45 000	Aft	Rough dry grass (Andover 30)	3 TO and land (Normal)	20.3.67
44 000	Fwd.	Medium rough grass (Andover 28)	6 TO and land (STOL 3° approach)	17.4.67
40 000	Fwd.	Rough damp grass (Andover 30)	3 TO and land (STOL)	19.4.67
40 000	Fwd.	Smooth dry grass	2 TO and land (Normal)	19.6.67
41 000	Mid	Medium rough dry grass (Upavon)	1 landing. (TO on PSNI membrane)	31.7.67
42 000	Mid	As above but grass wet after heavy rain	1 TO and landing	16.8.67

Table 3/

Table 3
Soft Surface Tests

Initial Weight	CG Posn.	Surface Condition	CBR % (Mean)	Test	Date
43 000	Mid	3 in. soft stony layer, dry	4-6 at 3" 6-9 at 6"	Taxying at 30-40-50 mph	27.7.66
43 000	Mid	" " " "	" "	Taxying at 65 kt.	29.7.66
38 000	Mid	Strip covered with piles of dead weed	0-1 in first 2 in. 2-4 at 3 in. 6 at 6 in.	1 TO and landing (STOL)	21.9.66
37 200	Fwd	3 in. soft, stony, dry	4 at 3 in. 7-9 at 6 in.	3 TO and landing (STOL)	26.9.66
41 000	Fwd	2 in. semi-liquid mud on frozen sub-grade	Not measurable in top 2 in. 2-3 in. crust with 10% then 5% to 8-9 in.	2 runs at normal taxi speed with 90° turns	12.1.67
37 000	Fwd	3 in. soft, stony, dry	2-3 at 3 in. 6 at 6 in.	4 TO and land (STOL)	30.3.67
40 000	Fwd	" " " "	2-3 at 3 in. 4-5 at 6 in. 9-10 at 9 in.	4 TO and land (STOL)	31.3.67
43 000	Fwd	3 in. soft, stony layer small local areas soft to 4-5 in. Dry	3-4 at 3 in. 4-5 at 6 in. 12-13 at 9 in. local spots 4 at 9 in.	7 TO and land	9.5.67
46 000	Fwd	As above	As above	3 TO and land	10.5.67
46 000	Fwd	As above	2 at 3 in. 4 at 6 in.	1 TO and land	31.5.67
44 000	Fwd	3 in. soft stony layer moisture 20.5% by weight	2 at 3 in. 4 at 6 in. 10 at 9 in.	6 TO and land	1.6.67
42 000	Aft	As above (25% moisture)	1-2 in. top 3 in. 4-6 at 3 in.	3 TO (Land on runway)	7.6.67
47 500	Aft	3 in. soft stony. Dry	0-1 in. top 3 in. 4 at 3 in. 6 at 6 in.	2 TO 1 landing	8.6.67
47 600	Aft	As above but moist at 3 in.	0-1 in. top 3 in. 4 at 3 in. 6 at 6 in.	6 TO and land	9.6.67
48 000	Fwd	3 in. soft stony. Dry	As above	3 TO and land	12.6.67
40 000	Fwd	6 in. soft stony. Dry	1/2 at 3 in. 2 at 6 in. 15 at 9 in.	2 TO 1 land (STOL)	15.6.67
40 000	Fwd	" " " "	1-2 at 3 in. 3-4 at 6 in. 15 at 9 in.	6 TO and land (STOL)	21.8.67
40 000	Aft	" " " "	As above but with some softening to greater depth in area of trafficking	6 TO (STOL) landings on runway	23.8.67

Note.- At weights above 42 000 lb., the technique used during landing was:-
3° approach, reverse thrust after touchdown, cancelled at first sign of movement of dust cloud forward of the wing. The use of wheel brakes varied in an effort to determine optimum use, but at weights in excess of 42 000 lb., full braking was generally used with brake release just prior to full stop to avoid soil build up.

Table 4

Artificial Bump Tests

Initial Weight	CG Position	Arrangement of bumps	Object of Test	Date
41 000	Fwd.	2" Bumps 1 per u/c	2 runs at 23 kts. (nominal)	29.9.66
41 000	Fwd.	As above	2 runs at 30-35 kts.	3.10.66
42 000	Fwd.	2" Bumps 2 per u/c at random intervals	2 runs at 45 kts. 1 run at 60 kts.	4.1.67
40 500	Fwd.	3" Bumps 2 per u/c at random intervals	1 run at 20-25 kts. 1 run at 30-35 kts. 1 run at 40-45 kts.	19.1.67
42 000	Fwd.	As above	Runs at 68, 77, 89 kts.	22.2.67
42 000	Aft	As above	4 runs using reverse thrust before first bump. 70, 72, 74, 75 kts. at entry to bump pattern.	8.3.67
45 000	Aft	As above	4 runs with reverse thrust 66, 75, 86, 98 kts. at entry	13.3.67
45 000	Fwd.	As above	2 runs with reverse thrust at 71, 74 kts. 4 landings attempted on the bumps but all short	14.3.67
42 000	Fwd.	As above	3 runs at 20, 40, 60 kts. 2 runs at 70 kts. with full wheel braking 1 run at 70 kts. with full reverse thrust 1 run at 70 kts. with full brake and reverse	17.5.67

Table 5/

Table 5

Undulation Tests

Initial Weight	CG Position	Undulation tested	Object of Test	Date
43 500	Mid	3 x 150 ft. ±6"	1 run at 30 kts. nominal (stick forward)	25.7.66
43 500	Mid	" " " "	1 run at 43 kts. nominal (stick forward)	26.7.66
43 000	Mid	" " " "	1 run at 60 kts. nominal (stick forward)	29.7.66
39 000	Mid	" " " "	1 take-off starting 650 ft. from 1st und. 1 take-off starting 350 ft. from 1st und.	21.9.66
39 000	Mid	" " " "	1 take-off starting 200 ft. from 1st und. 1 take-off starting 100 ft. from 1st und.	22.9.66
41 000	Fwd.	" " " "	2 take-offs starting 100 ft. from 1st und.	29.9.66
42 000	Mid	" " " "	1 slow taxi run 1 run 35 kts. (accelerating) 1 run 45 kts. (accelerating)	17.7.67
42 000	Fwd.	" " " "	1 run 20 kts. 1 run accelerating through 32 kts. (stick back) 1 run decelerating from 42 kts. 1 run decelerating from 48 kts. 1 run decelerating from 60 kts. 1 run accelerating thro' 50 kts. (stick back) 1 run accelerating thro' 50 kts. (stick neutral) 1 run accelerating thro' 50 kts. (stick free)	21.9.67
42 000	Aft	" " " "	1 run 30-40 kts. 27° Flap neutral trim 1 run 46 kts. " " " "	25.9.67
42 000	Aft	" " " "	1 run 30-40 kts. 1 run 45-47 kts. 1 run 60 kts.	13.10.67
43 500	Mid	3 x 75 ft. ±3"	1 run at 20 kts. (nominal) Stick forward	25.7.66
43 500	Mid	" " " "	1 run at 30 kts. (nominal) Stick forward	26.7.66
43 000	Mid	" " " "	1 run at 40 kts. (nominal) Stick forward	29.7.66
42 000	Mid	" " " "	1 slow taxi run 1 run 30 kts.	17.7.67
42 000	Mid	" " " "	1 run accelerating through 30 kts. 1 run accelerating through 30 kts. 1 run accelerating through 40 kts.	17.7.67
42 000	Fwd.	" " " "	1 slow taxi run 1 run accelerating thro' 35 kts., 27° Flap, neutral trim 1 run accelerating thro' 35 kts., 27° Flap, 2° NU trim 1 run accelerating thro' 37 kts., 0° Flap, 2° NU trim 1 run accelerating thro' 44 kts., 27° Flap, neutral trim	22.9.67
42 000	Aft	" " " "	1 run accelerating thro' 38-38 kts.	25.9.67
42 000	Aft	" " " "	1 run accelerating 30-35 kts. 1 run accelerating 40-50 kts.	13.10.67
43 500	Mid	3 x 50 ft. ±2"	1 run at 20 kts.	26.7.66
43 000	Mid	" " " "	1 run at 30-35 kts.	29.7.66
39 000	Mid	" " " "	1 run at 40 kts.	22.9.66
42 000	Aft	" " " "	1 run accelerating 35 kts. 1 run accelerating 42 kts. 1 run accelerating 46 kts. 1 run accelerating 58 kts. 1 Take-off	25.9.67

Table 6

Tests on 1 in 50 Ramps

Initial Weight-lb.	CG Position	Ramp Arrangement	Object of Test	Date
42 000	Fwd	2 x 3", 1 in 50 ramps at 15 ft. spacing	8 runs at speeds between 5-25 kts. Each undercarriage in turn over the ramps	21.6.67
42 000	Fwd	3 x 3", 1 in 50 ramps at 15 ft. spacing	1 traverse by nosewheels at 20 kts	21.6.67
42 000	Fwd	2 x 3", 1 in 50 ramps at 30 ft. spacing	9 runs at speeds between 20-50 kts. Each undercarriage in turn over the ramps	23.6.67
42 000	Fwd	3 x 3", 1 in 50 ramps at 30 ft. spacing	1 traverse by nosewheels at 40-45 kts.	23.6.67
42 000	Fwd	2 x 3", 1 in 50 ramps at 45 ft. spacing	9 runs at speeds between 40-60 kts. Each u/c in turn over the ramps.	27.6.67
42 000	Fwd	2 x 3", 1 in 50 ramps at 60 ft. spacing.	9 runs at speeds between 40-65 kts. Each u/c in turn over the ramps.	30.6.67
42 000	Mid	2 x 6", 1 in 50 ramps at 45 ft. spacing	7 runs at speeds between 10-40 kts. Each u/c in turn over the ramps.	21.7.67
42 000	Fwd	2 x 6", 1 in 50 ramps at 75 ft. spacing	3 runs at speeds between 5-25 kts. Ramps arranged to cover full 3 undercarriage width.	18 & 21 9.67
42 000	Aft	1 x 6" ramp 1 in 50 leading and trailing slope	4 runs at speeds between 25-55 kts. Full 3 u/c width.	27.9.67
42 000	Aft	2 x 6", 1 in 50 ramps at 135 ft. spacing	4 runs at speeds between 40-65 kts. Full 3 undercarriage width.	6.10.67
42 000	Aft	2 x 6", 1 in 50 ramps at 75 ft. spacing. 2 centre ramps with parallel trailing section	4 runs at speeds between 35-50 kts. Full 3 u/c width.	13.10.67

Table 7/

Table 7

Recommended Maximum Undercarriage Loads

Main u/c	Recommended Maximum	Nose u/c	Recommended Maximum
Vertical	40 000 lb.	Vertical	20 000 lb.
Drag	16 000 lb.	Drag	8 000 lb.
Side	10 000 lb.	Side	5 000 lb.
Differential Vertical	20 000 lb.		
Differential Drag	17 000 lb.		

Table 8

Recommended Maximum Component Loading

Main u/c	Recommended Maximum	Nose u/c	Recommended Maximum
Liquid Spring End Load	93 300 lb.	End load	26 700 lb.
Main Forging Side Bending	667 000 lb. in.	Drag Strut Bending	694 000 lb. in.
Main Forging Torsion	233 000 lb. in.	Side Bending	427 000 lb. in.
Wheel Lever Side Bending	360 000 lb. in.		
Drag Strut End Load	73 300 lb.		

Table 9/

Table 9

Summary of Maximum Loads Measured in Tests on Concrete

Item	Recommended Maximum Loads	Load Measured During Max. Braked 50 000 lb. Landing 23.6.66	Load Measured During 47 600 lb. Landing at 10 ft./sec. 28.6.66	Load Measured in 360° Turn at 50 000 lb. 23.6.66
Liquid Spring	93 300 lb.	65 000 lb.	70 000 lb.*	-
Drag Strut	73 300 lb.	44 000 lb.	40 000 lb.	-
Main Forging Side Bend	667 000 lb. in.	130 000 lb. in.	170 000 lb. in	180 000 lb. in.
Main Forging Torsion	233 000 lb. in.	30 000 lb. in.	15.000 lb. in	-
Wheel Lever Side Bend	360 000 lb. in.	-	50 000 lb. in.	-
Nose Leg End Load	26 700 lb.	14 000 lb.	12 000 lb.	-
Nose Drag Strut	694 000 lb. in.	100 000 lb. in	10 000 lb. in.	-
Nose Leg Side Bend	427 000 lb. in.	200 000 lb. in.	120 000 lb. in.	180 000 lb. in.

* In this example the resolved undercarriage vertical load was 37 500 lb. (40 000 permitted.) The rate of descent was obtained from ground and aircraft ROD camera records.

Table 10

Side Bending Loads in Tests On Concrete (see also Table 12)

Date	Aircraft Weight lb.	CG Posn.	Test Condition	Main w/c Side Load lb.	Bending Stress Wheel Lever Lug psi
14.7.66	43 000	Mid	STOL landing in 23 kts. crosswind. Measured rate of descent 9 ft./sec. Stbd. 6.5 ft./sec. Port.	7 200	59 000
2.9.66	38 000	Mid	STOL landing in 15 kts. crosswind. 1st by new pilot. 3° glidepath. 5° bank to Stbd. at touch-down 0.3 'g' lateral accn.	9 200 (Stbd.) 7 500 (Port)	55 000 (Tensile Stbd.) 75 000 (Comp. Port)

Note.- 1. The estimated elastic limit for the forging material is 50 000 psi.
2. Both the occasions in Table 10 were considered to be on or outside the limits of STOL operation.

Table 11

Results of Grass Surface Tests

Item	Recommended Maximum	Taxy. Wet Smooth Grass 43 000 lb.	Landing. Wet Smooth Grass 40-42 000 lb.	Landing. Smooth Grass 40 000 lb.	Upavon Taxy. Wet Rough Grass 40 000 lb.	Andover 30 Landing Rough Grass 42 000 lb. (Fwd.)
Liquid Spring lb.	93 300	60 000	51-64 000	25-50 000	60 000	58-67 000 (1 peak at 80 000)
Drag Strut lb.	73 300	35 000	28-36 000	15-33 000	36 500	26-42 000
Main Forging Side Bending lb.in.	667 000	150 000	82-183 000	100 000	240 000	40-150 000
Main Forging Torsion lb.in.	233 000	30 000	16-41 000	25 000	35-40 000	20-30 000 (1 peak at 65 000)
Wheel lever side bending lb.in.	360 000	100 000	47-93 000	30 000	120-170 000	50-125 000
Nose leg End load lb.	26 700	15 000	14-16 000	14 000	18 000	20 000
Nose Drag Strut lb.in.	694 000	50 000	130-210 000	-	180-300 000	100-280 000
Nose Leg Side Bending lb.	427 000	250 000	71-102 000	140 000	70-160 000	75-100 000
CRBS		2 at 1 in. 5 at 3 in.	2 at 1 in. 5 at 3 in.	4 at 1 in. 6 at 3 in.	0-2 at surface 3 at 3 in. 10 at 5 in.	3 at surface 2 at 1 in. 3 at 3 in. 5 at 6 in.

Table 11 (contd.)

Table 11 (Contd.)

Results of Grass Surface Tests (Contd.)

Item	Recom- mended Maximum	Andover 28 Med. Rough Grass 42 500- 44 000	Andover 28 and 30 (Rev. thrust landings at 45 000 lb. only)		Abingdon Taxy. Rough Grass 42 000 lb.	Andover 30 Braked Landings. Rough Grass 42 000 lb. (Fwd. CG)
			Runway 28	Runway 30		
Liquid Spring lb.	93 300	54-67 000	54-57 000	56-64 000	52-60 000	58-70 000
Drag Strut lb.	73 300	26-33 000	26-31 000	28-33 000	30-34 000	29-35 000
Main Forging Side lb.in. Bending	667 000	80-160 000 (1 peak 250 000)	80-16 000	80-140 000	100 000	50-100 000
Main Forging lb. Torsion in.	233 000	20-40 000	10-28 000	17-28 000	22 000	20-30 000
Wheel Lever Side lb.in. Bending	360 000	75-160 000	48-105 000	32-105 000	48-60 000	30-60 000
Nose Leg End lb. Load	26 700	23-26 000	17 500	22 500 - 27 600	26 000	18-31 000*
Nose Drag lb.in. Strut	694 000	140-28 500	60-220 000	150-190 000	320 000	180-280 000
Nose Leg Side lb.in. Bending	427 000	85-125 000	60-90 000	135-160 000	160 000	100 000
CBR%	-	4 at surface, 6 at 3 in.	3 at surface, 2 at 1 in, 4 at 3 in, 5 at 6 in.		1 at 1 in., 2 at 3 in., 4 at 6 in.	3 at surface 3 at 3 in., 5 at 6 in.

* Investigation by Dowty Rotol showed that while the vertical load was high, the combination of vertical drag and side loads did not reach the design figures for parts considered critical. Inspection of bottom forging attachment pin revealed no damage. The test result illustrates the range of end load recorded from a maximum braking condition (31 000 lb.) down to the use of reverse thrust only above normal taxi speeds (18 000 lb.) on near limiting roughness.

Table 12/

Table 12

High Side Bending Loads Recorded During Taxying on Rough Grass

Aircraft Weight lb.	CG Position	Event	Wheel lever lug bending stress psi	Remarks
37 000	Forward	Turning during taxying. Approx. 150 ft. radius at estimated 20 knots. Medium and rough grass.	1. 54 000 Tens.Stbd. 2. 38 000 " Port 3. 57 000 " " 4. 62 000 " " 5. 45 000 " " 6. 62 000 " " 7. 65 000 " "	Strain gauges indicated possible yield. Observer's estimated turning speed in excess of pilot's estimate of 20 kts. Forging elastic range limit = 50 000 psi.

Table 13/

Table 13

Results of Tests on Soft Surfaces

Item	Recom- mended Maxima	21.9.66 TO & Landing on Soft Strip (3 in.) 38 000 lb. Mid. CG	30.3.67 TO & Landing on Soft Strip (3 in.) 37 000 lb. Fwd. CG	31.3.67 TO & Landing on Soft Strip (3 in.) 40 000 lb. Fwd. CG	9.5.67 TO & Landing on Soft Strip (3 in.) 43 000 lb. Fwd. CG	12.6.67 TO & Landing on Soft Strip (3 in.) 48 600 lb. Fwd. CG	21.8.67 TO & Landing on Soft Strip (6 in.) 40 000 lb. Fwd. CG
Liquid Spring lb.	93300	46 000-65 000	49 000-68 000	46 000-66 000	47 500-67 500	48 500-63 000	48 000-70 500
Drag Strut lb.	73300	29 000-35 000	29 600-37 000	28 000-39 000	27 500-36 500	31 000-40 500	29 000-41 500
Main Forging Side Bending lb.in.	667000	150 000-170 000	70 000-200 000	80 000-172 000	93 500-163 000	72 000-150 000	130 000-256 000
Main Forging Torsion lb.in.	233 000	15 000-55 000	27 000-51 000	7 000-55 000	26 500-64 500	26 000-50 000	21 500-67 400
Wheel Lever Side Bending lb.in.	360000	40 000-120 000	37 000-180 000	60 000-115 000	25 000-117 000	57 500-94 500	106 000-138 000
Nose Leg End Load lb.	26700	12 000-15 000	17 000-20 000	8 000-18 000	16 500-28 900*	15 000-20 000 (Estimated)	15 000-22 500
Nose Drag Strut lb.in.	694000	180 000-240 000	160 000-440 000**	72 000-240 000	100 000-440 000**	183 000-225 000	210 000-432 000**
Nose Leg Side Bending lb.in.	427000	100 000-150 000	90 000-140 000	140 000-215 000	110 000-215 000	188 000-202 000	129 000-263 000**
CBR%		0-1 for first 2in. 2-4 at 3 in. 6 at 6 in. 10 at 9 in.	0-1 for first 3in. 2-3 at 3 in. 6 at 6 in.	0-1 for first 3in. 2-3 at 3 in. 4-5 at 6 in. 9-10 at 9 in.	0-2 for first 3in. 3-4 at 3 in. 4-5 at 6 in. Local spots 4 at 9 in.	0-1 for first 3in. 4 at 3 in. 6 at 6 in.	0-1 for first 3in. 1-2 at 3 in. 3-4 at 6 in. 15 at 9 in.
		(i)	(ii)	(iii)	(iv)	(v)	(vi)

* This was a single peak load which although high, the combination of vertical, drag and side loads did not reach the design figures. Bottom forging attachment pin inspected and found satisfactory.

** The isolated peak nose drag and side bending loads were within the proof limits.

Table 14
Results of Discrete Bump Tests

Date and Test Object		16.1.67 2 runs at 45 kts. 1 run at 60 kts.	19&22.1.67 runs between 20-89 kts.	13.3.67 runs at 66-98 kts. with reverse thrust	14.3.67 runs at 71-74 kts. 4 landings	17.5.67 Runs at 20-70 kts. Brakes and Reverse
Aircraft Wt. lb.		42 000	40 000-42 000	45 000	45 000	42 000
CG Position		Fwd.	Fwd.	Aft	Fwd.	Fwd.
Bump Size and Arrangement		2 in., 2 per u/c Random Spacing	2 in., 2 per u/c Random Spacing	3 in., 2 per u/c Random Spacing	3 in. 2 per u/c Random Spacing	3 in., 2 per u/c Random Spacing
Item	Recommended Max. Load					
Liquid Spring lb.	93 300	45 000	46 000	45 000	50 000	55 000
Drag Strut lb.	73 300	20 000	27 000	24 000	25 000	39 000
Main Forging Side Bending lb.in.	667 000		125 000	100 000	100 000	93 500
Main Forging Torsion lb.	233 000		27 000	15 000	20 000	18 000
Wheel Lever Side Bending lb.in.	360 000		75 000	50 000	50 000	50 000
Nose Leg End Load lb.	26 700	12 000	14 000	8 000	10 000	12 500
Nose Drag Strut lb.in.	694 000	183 000	210 000	310 000	320 000	350 000
Nose Leg Side Bending lb.in.	427 000		212 000	160 000	120 000	82 000

- Notes.-
1. These loads are the maxima measured during several runs in each sortie. The maxima for the individual components are not co-incident.
 2. The actual spacing of the bumps for these tests is shown in Fig.4a.

Table 15(a)/

Table 15(a)

Peak Loads Recorded During Tests on 3 x 150 ft ± 6 in. undulations

Date and Test Object		25.7.67 1 Run at 30 kts.	26.7.67 1 Run at 43 kts.	29.7.67 1 Run at 60 kts.*	17.7.67 2 Runs at 35 kts. 45 kts. Accelerating	21.9.67 Decelerating From 60 kts.	21.9.67 Accel. Through 50 kts.	21.9.67 Accel. Through 50 kts.	21.9.67 Accel. Through 50 kts.*	13.10.67 Accel. 30-40 kts.	13.10.67 Accel. Through 60 kts.*
Aircraft Weight		43 500	43 500	43 500	42 000	42 000	42 000	42 000	42 000	48 000	42 000
CG Position		Mid	Mid	Mid	Mid	Fwd	Fwd	Fwd	Fwd	Aft	Aft
Remarks on Control Position During Test		Stick Fwd	Stick Fwd	Stick Fwd	Stick Aft	Stick Neutral	Stick Aft	Stick Neutral	Stick Free	Stick Neutral	Stick Neutral
Item	Recommended Max. Load										
Liquid Spring lb.	93 300	60 000	65 000	60 000	59 000	48 000	39 500	48 000	48 500	49 000	46 500
Drag Strut lb.	73 300	35 000	35 000	35 000	35 000	18 500	18 500	27 000	22 000	25 000	25 000
Main Forging Side Bending lb. in.	667 000	140 000	140 000	100 000	80 000	-	-	-	-	105 000	84 000
Main Forging Torsion lb. in.	233 000	20 000	20 000	20 000	30 000	38 000	44 000	46 000	49 500	14 600	17 500
Wheel Lever Side Bending lb. in.	360 000	100 000	90 000	75 000	60 000	32 000	32 000	70 000	72 000	70 500	38 500
Nose Leg End Load lb.	26 700	16 000	13 000	>28 000 ^x	11 000	19 000	14 500	18 000	19 000	14 000	16 000
Nose Drag Strut lb. in.	694 000	-	-	50 000	170 000	100 000	110 000	130 000	185 000	72 000	105 000
Nose Leg Side Bending lb. in.	427 000	160 000	170 000	150 000	120 000	155 000	180 000	155 000	280 000	157 000	110 000
		(i)	(ii)	(iii)	(iv)	(v)	(vi)	(vii)	(viii)	(ix)	(x)

* Tests marked thus resulted in violent pitching accompanied, in the cases marked x, by high nose leg end loads which damaged the strain gauges at the bottom of the sliding tube. The loads quoted in these cases were estimated from the strain gauge trace and nose leg closure, prior to the failure.

Table 15 (b)

Peak Loads Recorded during Tests on 3 x 75 ft. ± 3 in. undulations

Date and Test Object	25.7.66 1 Run at 20 kts.	26.7.66 1 Run at 30 kts.	29.7.66 1 Run at 40 kts.*	17.7.67 1 Run Accel. Through 40 kts.*	22.9.67 Accel. Through 35 kts.	22.9.67 Accel. Through 44 kts.*	13.10.67 Accel. Through 35 kts.	13.10.67 Accel. Through 45 kts.*
Aircraft Weight	43 500	43 500	43 500	42 000	42 000	42 000	42 000	42 000
CG Position	Mid	Mid	Mid	Aft	Fwd	Fwd	Aft	Aft
Remarks on Control Position During Test	Stick Fwd	Stick Fwd	Stick Fwd	Stick neu- tral to aft	27° Flap Stick neutral	27° Flap Stick neutral	27° Flap Stick neutral	27° Flap Stick neutral
Item	Recommended Max. Load							
Liquid Spring lb.	93 300	60 000	75 000	75 000	57 000	56 000	59 000	48 500
Drag Strut lb.	73 300	35 000	40 000	37 000	35 000	31 500	32 500	26 000
Main Forging Side Bending lb. in.	667 000	140 000	150 000	150 000	80 000	96 500	240 000	63 000
Main Forging Torsion lb.in.	233 000	20 000	20 000	40 000	20 000	25 000	23 000	12 500
Wheel Lever Side Bending lb. in.	360 000	100 000	100 000	100 000	60 000	49 500	50 000	49 500
Nose Leg End Load lb.	26 700	16 000	20 000	>28 000 ^x	19 000	19 500	28 600 ^x	16 000
Nose Drag Strut lb.in.	694 000	-	80 000	80 000	120 000	131 000	268 000	105 000
Nose Leg Side Bending lb. in.	427 000	160 000	150 000	100 000	120 000	163 000	172 000	98 000
	(i)	(ii)	(iii)	(iv)	(v)	(vi)	(vii)	(viii)

* Tests marked thus resulted in violent pitching accompanied, in the cases marked x, by high nose leg end loads which damaged the strain gauges at the bottom of the sliding tube. The loads quoted in these cases were estimated from the strain gauge trace and nose leg closure, prior to the failure.

Table 15(c)

Peak Loads Recorded During Tests on 3 x 50 ft. ± 2 in. undulations

Date and Test Object		26.7.66 1 Run at 20 kts.	29.7.66 1 Run at 30 kts.	22.9.66 1 Run at 40 kts.	25.9.67 Accel. Through 35 kts.	25.9.67 Accel. Through 42 kts.	25.9.67 Accel. Through 46 kts.	25.9.67 Accel. Through 58 kts.	25.9.67 Take-Off
Aircraft Weight		43 500	43 500	39 000	42 000	42 000	42 000	42 000	42 000
CG Position		Mid	Mid	Mid	Aft	Aft	Aft	Aft	Aft
Remarks on Control Position During Test		Stick Fwd	Stick Fwd	Stick Fwd	Stick neutral 27° Flap	Stick neutral 27° Flap	Stick neutral 27° Flap	Stick neutral 27° Flap	
Item	Recommended Max. Load	← Recorded Loads →							
Liquid Spring lb.	93 300	55 000	55 000	35 000	49 000	44 000	43 000	35 000	45 500
Drag Strut lb.	73 00	30 000	30 000	25 000	27 000	26 500	27 000	24 000	24 500
Main Forging Side Bending lb. in.	667 000	50 000	75 000	-	43 000	47 500	65 500	-	53 500
Main Forging Torsion lb.in.	233 000	10 000	20 000	-	11 000	-	11 000	16 500	12 000
Wheel Lever Side Bending lb. in.	360 000	50 000	80 000	-	40 000	40 000	54 500	53 000	61 000
Nose Leg End Load lb.	26 700	10 000	14 000	11 000	-	13 500	-	-	-
Nose Drag Strut lb.in.	694 000	20 000	20 000	-	120 000	115 000	150 000	85 000	88 000
Nose Leg Side Bending lb. in.	427 000	100 000	75 000	-	89 000	90 000	95 000	87 500	199 000
		(i)	(ii)	(iii)	(iv)	(v)	(vi)	(vii)	(viii)

Table 16(a)/

Table 16(a)

2 x 3 in. 1 in 50 slope ramps (Test Results)

Ramp Spacing		15	30	45	60
Item	Recommended Max. Load	← Recorded Peak Loads →			
Liquid Spring lb.	93 300	52 500	51 500	40 000	43 500
Drag Strut lb.	73 300	30 000	27 000	22 500	23 500
Nose Leg End Load lb.	26 700	10 000	12 000	<14 000	13 500
Nose Drag Strut lb.in.	694 000	170 000	112 000	-	150 000
Nose Leg Side Bending lb. in.	427 000	25 000	56 500	35 500	62 500
		i	ii	iii	iv

Table 16(b)/

Table 16(b)

6 in. 1 in 50 slope ramps (Test Results)

	Ramp Arrangement and Method of Test	A/C Weight and CG	Speed	Recorded Component Peak Loads			
				Liquid Spring Recommended (Max. 93 300 lb.)	Drag Strut Recommended (Max. 73 300 lb.)	Nose End Load Recommended (Max. 26 700 lb.)	Nose Drag Load Recommended (Max. 694 000 lb. in.)
i	2 x 6 in. ramps at 45 ft. spacing. Each under-carriage traversing ramp separately.	42 000 lb. Mid	30 kts.	57 000	29 000	-(Not Significant)	98 000
ii	2 x 6 in. ramps at 75 ft. spacing. Full a/c width.	42 000 lb. Fwd	16 kts.	61 000	33 000	21 000	36 000
iii	2 x 6 in. ramps at 75 ft. spacing. Full a/c width. Nose wheel ramps with parallel extensions.	42 000 lb. Aft	35-40 kts. 40-45 kts. 45-50 kts.	59 000 58 000 59 500	30 000 27 500 30 500	19 500 (Est) 17 000 (Est) 19 500 (Est)	150 000 124 000 127 500
iv	2 x 6 in. ramps at 135 ft. spacing	42 000 lb. Aft	40 kts. 50 kts. 65 kts.	51 500 43 000 51 500	28 000 25 500 29 500	Not Significant " " " "	108 000 91 500 88 500
v	1 x 6 in. ramp with 1 in 50 leading and trailing edge	42 000 lb. Aft	25 kts. 35 kts. 43 kts. 55 kts.	49 500 55 000 51 000 39 500	30 000 29 000 28 000 23 500	16 500 15 000 15 000 10 000	131 000 91 500 81 700 65 500

Note.- Other component loads are not shown in these tables as they were not significant.

Table 17

Bending Moment Records

No. of TO and Landings	Test Site	Counting levels of Bending Moment (10 ⁶ lb. in.)							
		Station	Port wing 1/B		Port wing 0/B			Fuselage	
		Level	+2.0	-2.0	+2.0	+1.0	-1.0	+2.0	-2.0
2	Abingdon Grass		2	0	0	7	0	0	2
4	Andover Grass		4	0	0	13	0	2	5
5	Andover Grass		6	0	2	22	2	2	6
	Taxying 3" bumps {		0	0	0	5	0	0	0
	A & ARE }		0	0	0	3	1	0	0
4	Landings 3" bumps		4	0	0	5	0	0	1
6	Andover Grass		6	0	0	6	0	2	1
4	Ploughed strip		4	0	0	4	0	0	4
4	Ploughed strip		4	0	0	4	0	0	4
7	Andover Rough Grass		7	0	0	10	0	3	11
36	Total		37	0	2	79	3	9	34

APPENDIX I

Andover C. Mk. 1 - Airfield Criteria Trials
Report on the Use of a MEXE Profilometer

1. Introduction

During the Andover C. Mk. 1 Airfield Criteria trials the profiles of all the surfaces, on which the aircraft was employed, were examined with the aid of the prototype MEXE Profilometer. A number of the surfaces were also accurately surveyed. Comparisons of the results of the two methods of profile determination are given in Figs. 4 to 7 and it may be stated that the profilometer provides a useful measure of comparative roughness.

Undulated ground in excess of 3 in. in peak to trough height and having wave-lengths up to 200 ft. can be readily detected and measured with reasonable accuracy. Smaller bumps up to 3 in. in height may be detected and measured with an estimated accuracy of ± 1 in.

The present method of profile recording; i.e., on Polaroid film, necessitates a series of short traces over the width of the film, the amount of traversed ground represented by each trace being dependent on the drive gearing selected. Automatic flyback is provided from the end of one trace to the beginning of the next. This procedure, together with the lack of event identification, renders the determination of an accurate horizontal scale difficult. The estimated horizontal accuracy of measurement is $\pm 7\%$ when using high gear drive (nominal 400 ft. scale) and $\pm 2\%$ in low gear (nominal 4000 ft. scale). These estimates are based on measurements of separate traces and do not include errors introduced by trace flyback.

The profilometer proved fairly reliable in use, but some difficulty was experienced with the insertion and removal of Polaroid film. The device is heavy and awkward to handle when not fitted to a vehicle and the ground follower wheel and arm disintegrated twice during trials.

2. Description of Profilometer (see Fig. 1)

The instrument is contained within a rigid framework covered with panels with suitable brackets and clamps for attaching to the vehicle.

Projecting from the framework is a ground follower biased against the ground by a tension spring. Attached to the ground follower is a flexible cable which is connected to the film carrier.

To eliminate vehicle effects on the ground follower, a stable platform is provided consisting of a critically damped 10 sec. pendulum. This consists of a horizontal spindle carrying an arm about 3 ft. long. At the end of the arm is an aluminium vane which runs between two adjustable permanent magnets to provide eddy current damping. The pendulum is balanced by two springs fixed to the frame at one end attached to the pendulum spindle by a knife edged anchorage which is adjustable in vertical and horizontal planes to give the correct period of oscillation. The pendulum swings through 30° to give a ± 10 in. movement. Fixed to the pendulum spindle are two mirrors, one of which rotates with the spindle, the other is fixed to an arm at $1\frac{1}{2}$ in. radius.

The projection lamp is a "micro-lite" bulb, focussed by a lens on to the film, and is positioned in front of the rotating mirror.

A "Polaroid Land" 4 x 5 film holder is mounted in vertical guides. The holder accepts standard 4 x 5 Polaroid Polapan Type 52 film having a development time of 10 seconds. The cable from the ground follower is such that a rise in film carrier corresponds to a rise in ground follower.

The ground profile is recorded on the film by a horizontally moving light spot, deflected in a vertical plane by movement of the film holder or by the mirror at $1\frac{1}{2}$ in. radius on the pendulum spindle.

The horizontal movement of the light spot is caused by a cam operated mirror. Five horizontal scans are made across the film and the vertical separation between scans is caused by a ratchet operated rotary mirror between lamp and lens. When the end of the fifth scan has been reached, the drive is disconnected by a micro-switch operated solenoid. The mechanism is reset by the solenoid and is driven by a flexible cable to the vehicle front wheel. The scanning mechanism and film holder are enclosed in a light tight box.

3. Operation of Instrument (see Fig. 2)

3.1 The instrument was fitted to a long wheel base Land Rover. Calibration runs were made over standard one, two and three inch bumps at known intervals, (see Fig. 3). The 400 and 4000 ft. ranges referred to are the two nominal gearings of the machine.

3.2 From this the device was taken over undulations of known wave-length and height. Runs were then made at various strips on the airfields at A & AEE, Andover and Upavon Gallops, (see Figs. 4-8).

3.3 Survey readings were taken at 2 foot intervals for various strips for comparison with the profilometer records. (See Figs. 4, 5, 6 and 7).

3.4 The following points were noted during operation of the instrument:-

- (i) To set up either the "400" or "4000" feet scale the operator had to descend from the vehicle and manually change the flexible drive cable from one input shaft to another.
- (ii) The ground follower wheel had to be raised and tied with string when not required for use, i.e., when moving from one test site to another as it was not possible to manoeuvre the vehicle with the wheel in contact with the ground owing to excessive side load when turning.
- (iii) The method of attachment of the ground follower wheel gave trouble during trials. The locating pin became detached on a sharp bump with the subsequent loss of the wheel.
- (iv) Range changing and wheel raising and lowering were laborious resulting in the risk of a wasted recording due to the wrong range being selected or the film being fully exposed before the end of the selected test run.

3.5 The following failures were noted in operation:-

- (i) Loss of ground follower wheel at 15 mph on severe bump.
- (ii) The ground follower cable became detached, due to an insecure fastening.

(iii)/

- (iii) The ground follower retaining spring bracket turned and fouled the pendulum spring.
- (iv) The bolt holding the permanent magnet became loose and prevented movement of the pendulum.

3.6 The traces were difficult to read when obtained. The fly back from one traverse of the film to the next meant that part of the trace was lost.

3.7 Fitting the polaroid frame carrier into the instrument was very difficult if premature film exposure was to be avoided.

4. Recommendations

4.1 The MEXE Profilometer should be developed to a production standard incorporating the following specific recommendations for improvement.

4.2 An improved recording system is required, using for example, a portable trace recorder mounted in the vehicle, capable of giving an instantaneous read-out of roughness or wave-length against distance covered, with the additional provision of an event marker (see Fig. 9).

4.3 It should be possible to change the range of the profilometer from within the vehicle either by providing a remotely controlled gearbox or, as a feature of 4.2., a variable recording speed.

4.4 The ground follower arm and wheel mounting should be strengthened, made easily detachable and provided with a stowage within the main unit.

4.5 The long term pendulum and ground follower mechanism should be capable of being locked for transport.

SK B6012 REPORT NO 11TH PART / 943/1 A/C ANDOVER C MKI. CH MR GRANT APP *Rev. for S of E. 15 10 68 R.*

22-2-67 CALIBRATION
2" BUMPS AT 10' INTERVALS
400' RANGE - 15 M.P.H.

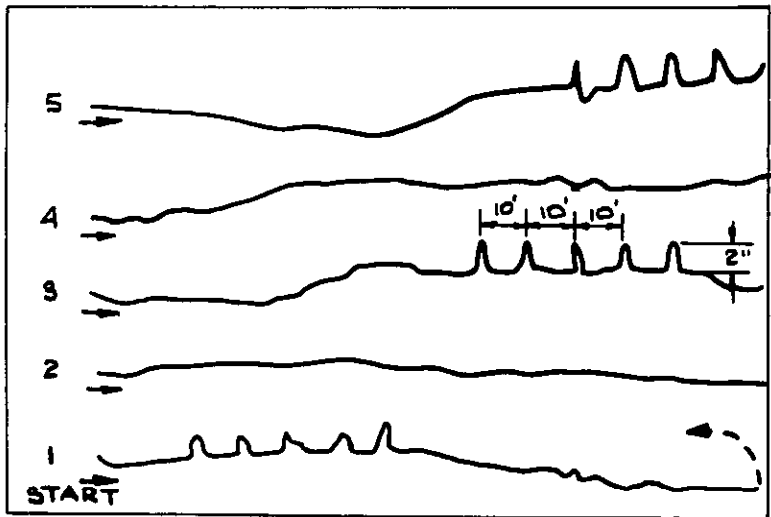

2-3-67 CALIBRATION
1", 2", 3" & 2" BUMPS AT 40,
30 & 30' INTERVALS
RESPECTIVELY
400' RANGE - 15 M.P.H.

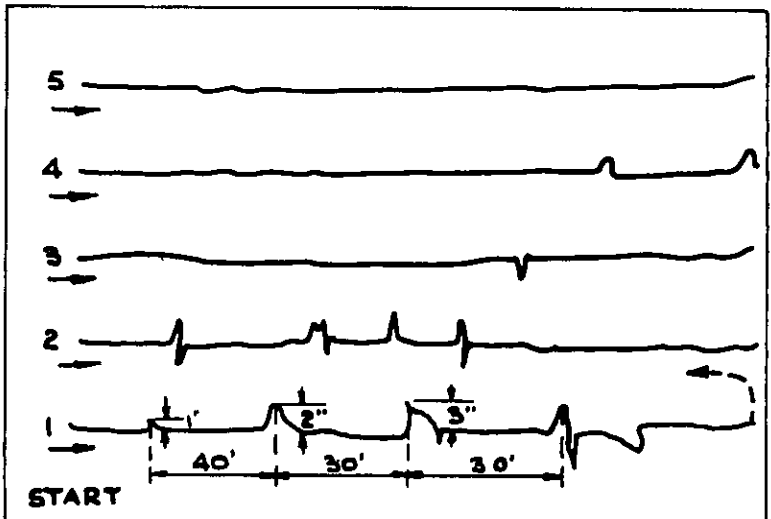

CALIBRATION
A 22 2-67
2" BUMPS AT 10' INTERVALS
4,000' RANGE - 15 M.P.H.

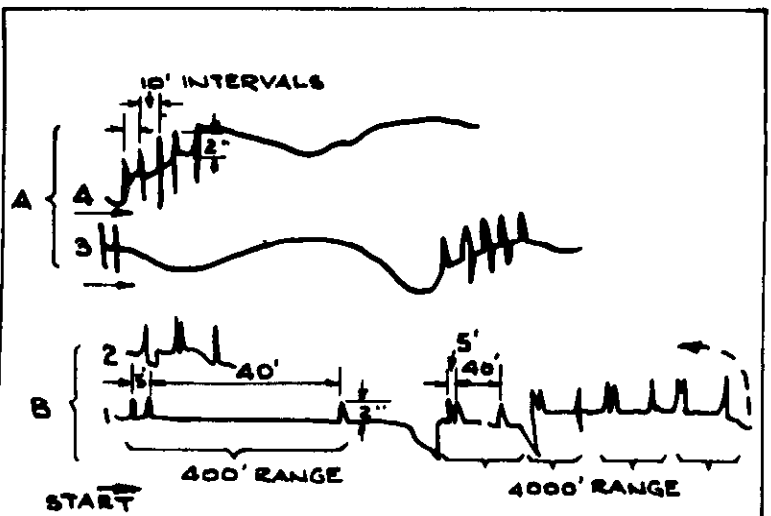

B 1-3-67
THREE 2" BUMPS AT 5' &
40' INTERVALS.
400' & 4,000' RANGE - 15MPH

AIRFIELD CRITERIA TRIALS.
MEXE PROFILOMETER RECORDS

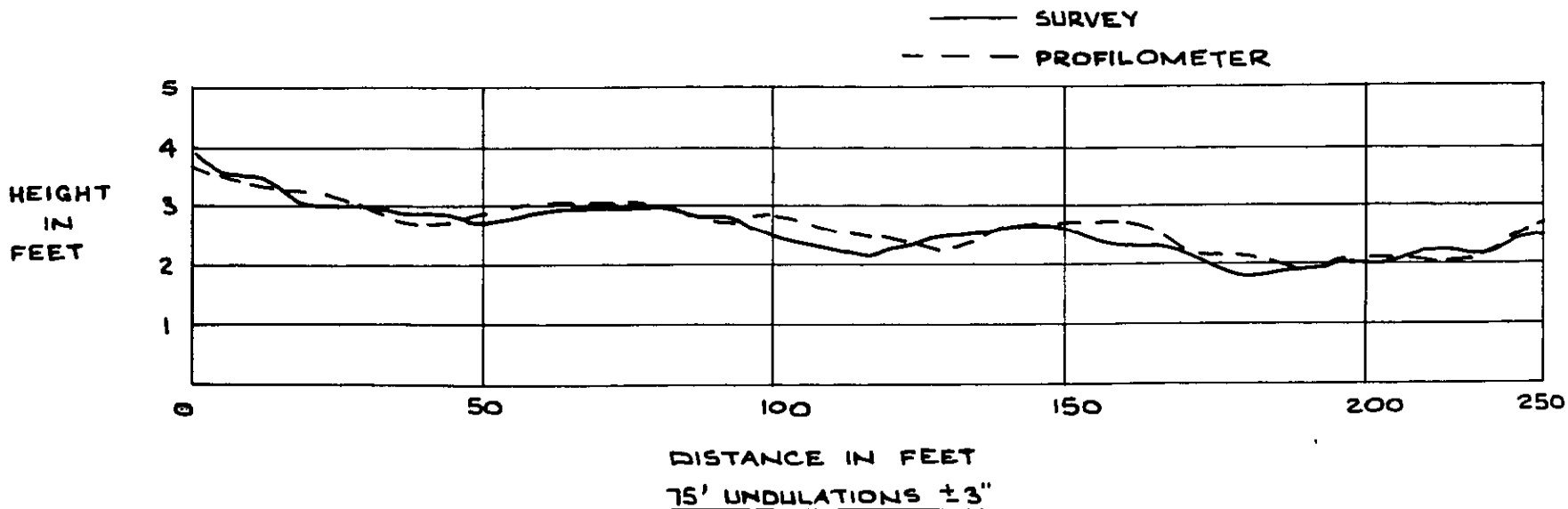
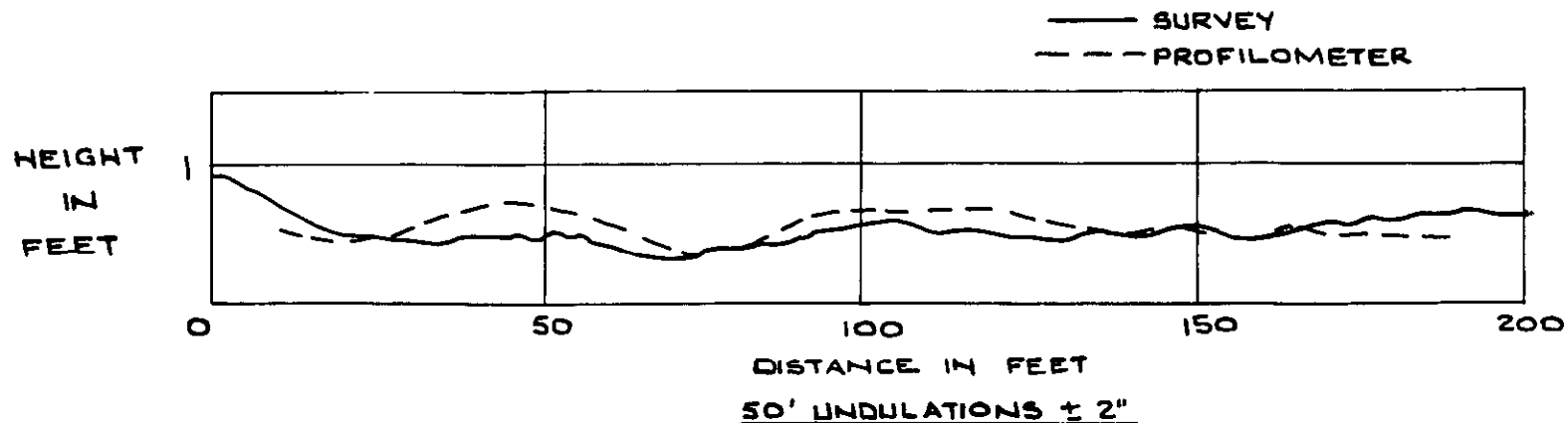

AIRFIELD CRITERIA TRIALS, COMPARISON OF MEXE PROFILOMETER RECORDS WITH ACTUAL SURVEY.

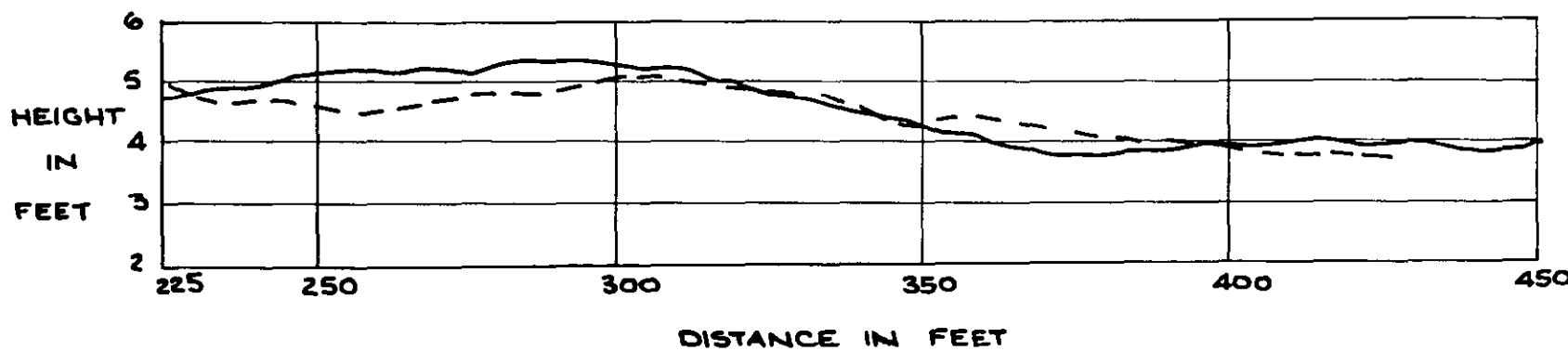
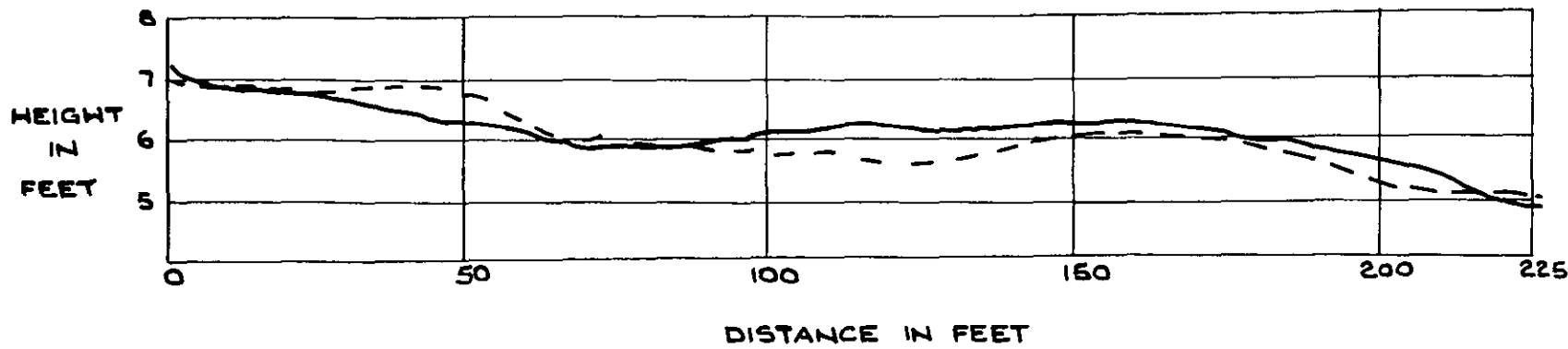

150' UNDULATIONS ± 6"

AIRFIELD CRITERIA TRIALS. COMPARISON OF MEXE PROFILOMETER RECORDS WITH ACTUAL SURVEY

R.A.F. ANDOVER RUNWAY 30/12 GRASS

NOTE:-

THE PROFILOMETER TRACE WAS RECORDED PARALLEL TO THE CENTRE LINE SURVEY AS NO CENTRE LINE WAS MARKED. THE COMPARISON SHOWN WAS RECORDED WITHIN THE VERTICAL HEIGHT RANGE OF THE PROFILOMETER IS"

— — — — — PROFILOMETER
 ————— SURVEY

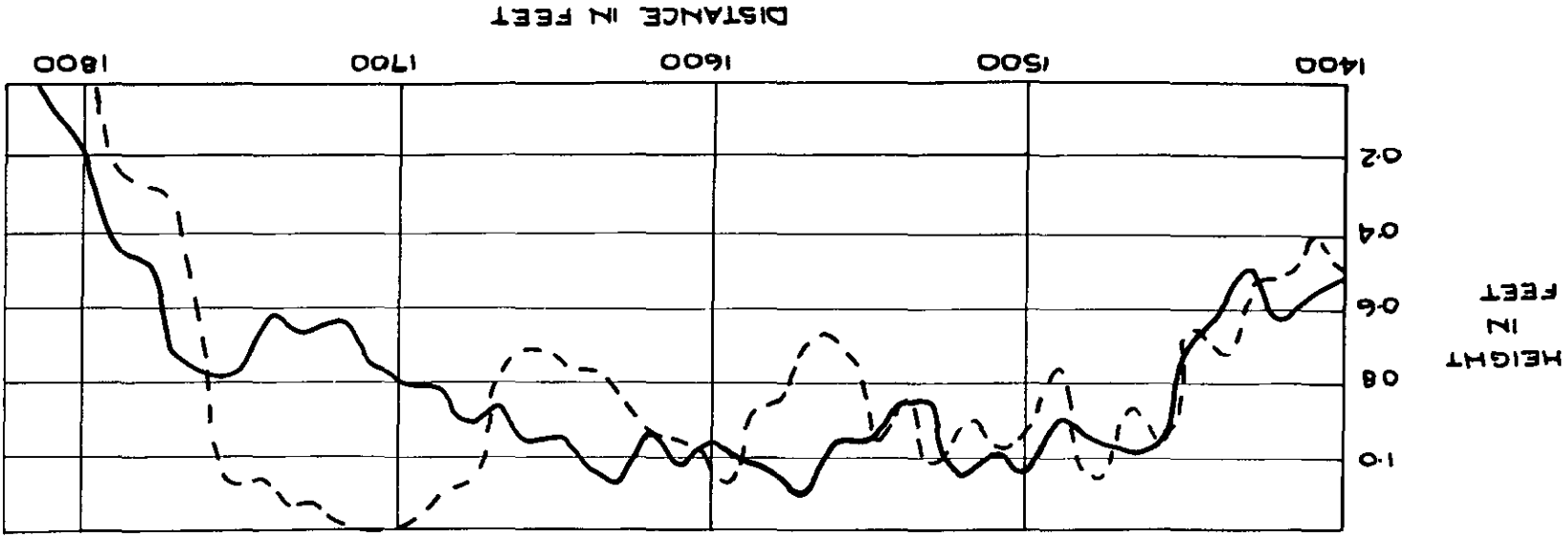

AIRFIELD CRITERIA TRIALS, COMPARISON OF MEXE PROFILOMETER RECORDS WITH ACTUAL SURVEY.

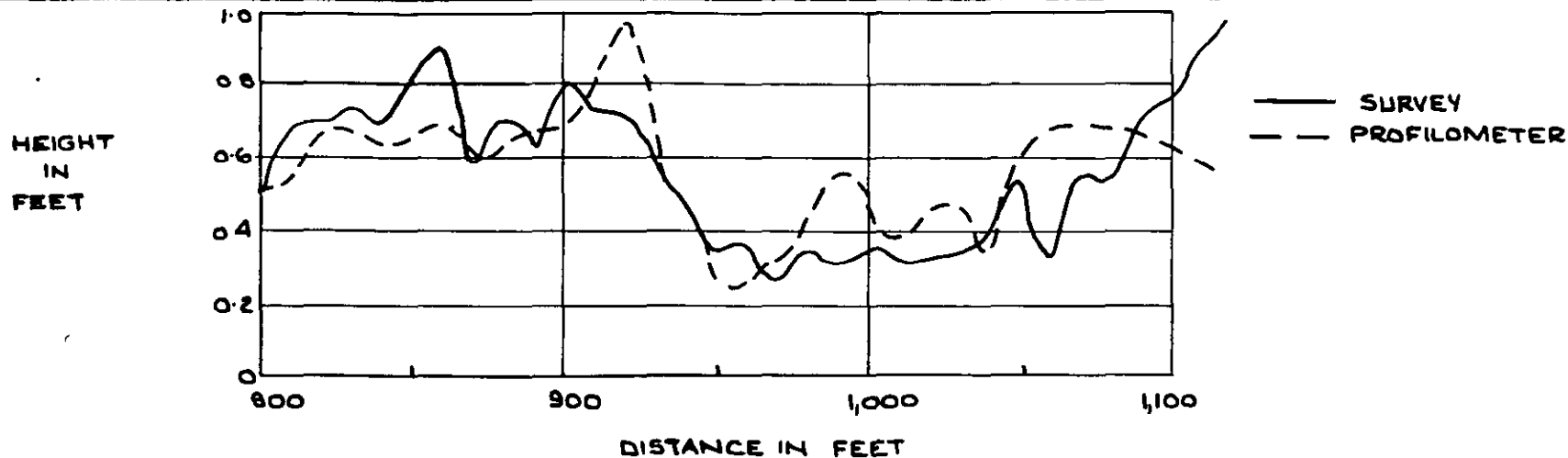

NOTE:- TRACE PARALLEL TO SURVEY BUT PROBABLY NOT COINCIDENT EXTRACTS SHOWN WERE RECORDED WITHIN VERTICAL HEIGHT RANGE OF PROFILOMETER.

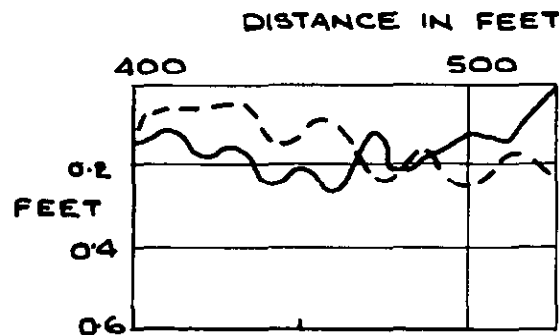
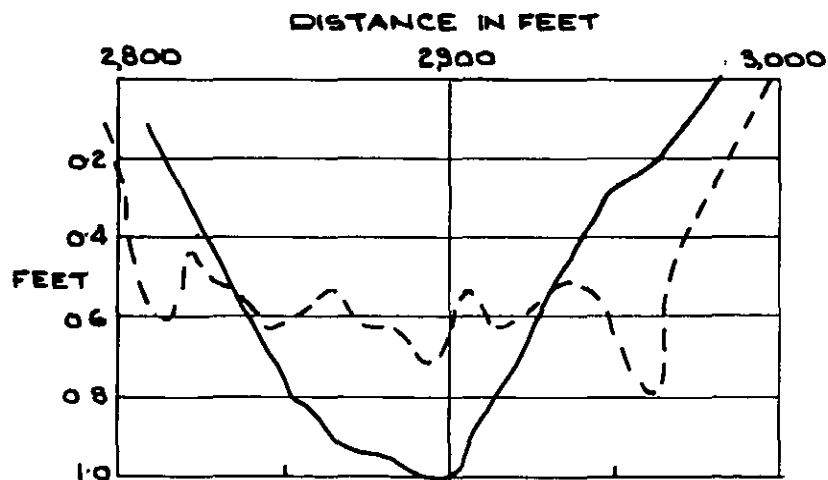

R A F ANDOVER RUNWAY 30/12 GRASS

AIRFIELD CRITERIA TRIALS COMPARISON OF MEXE PROFILOMETER RECORDS WITH ACTUAL SURVEY.

SK B 6017 REPORT No 11TH PART / 943/1 | A/C ANDOVER C MKI CH MR GRANT | APP RW for S of E | 15 10 60RS

PROFILOMETER TRACE. OVER 150 FT. UNDULATIONS. A & A E.E. 4,000' RANGE

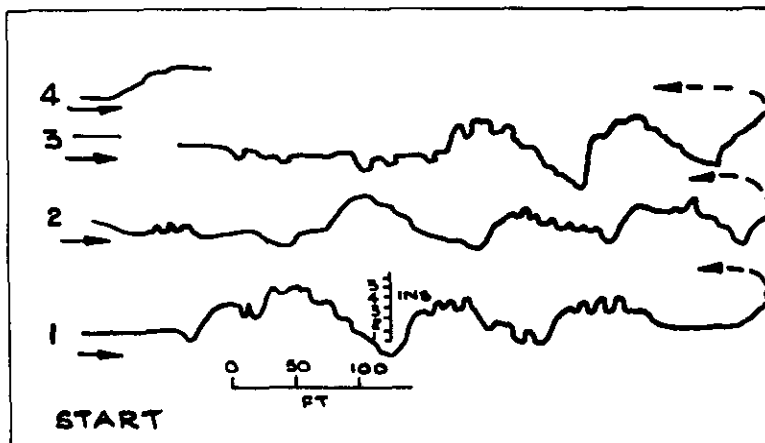

PROFILOMETER TRACE. ANDOVER RUNWAY 12 4,000' RANGE

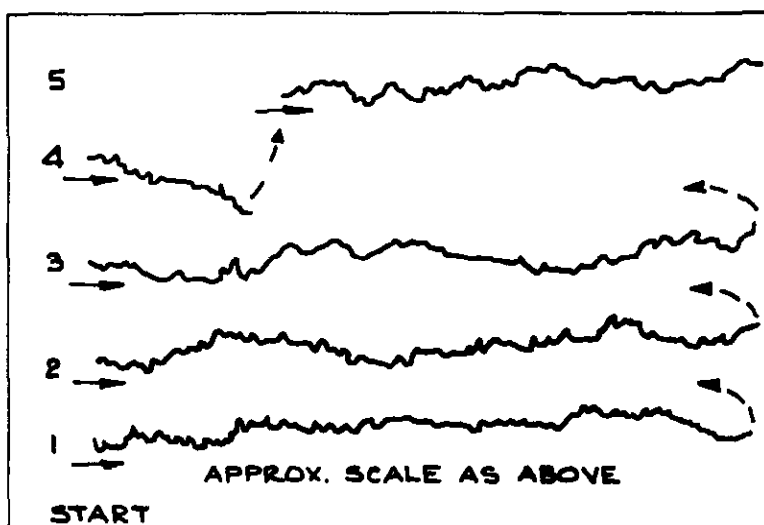

PROFILOMETER TRACE. LPAVON GALLOPS. DIRECTION 210 4,000' RANGE.

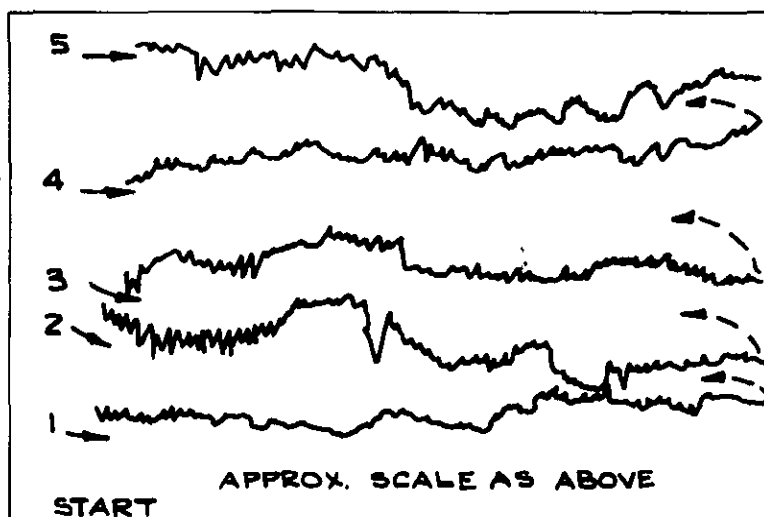

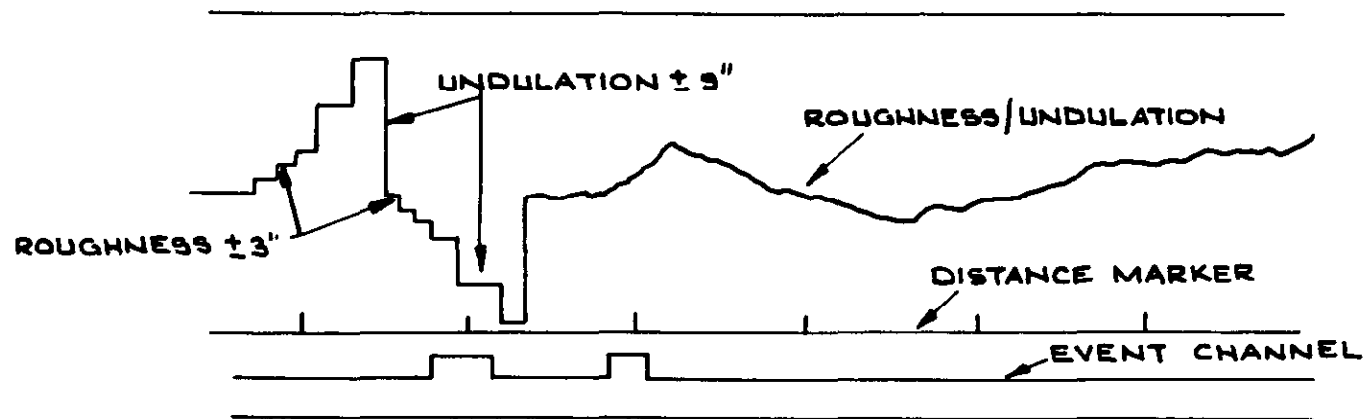

AIRFIELD CRITERIA TRIALS. SUGGESTED METHOD OF TRACE RECORD. PRESENTATION FOR MEXE PROFILOMETER.

FIG 1.

12 943 3 2700 943/1

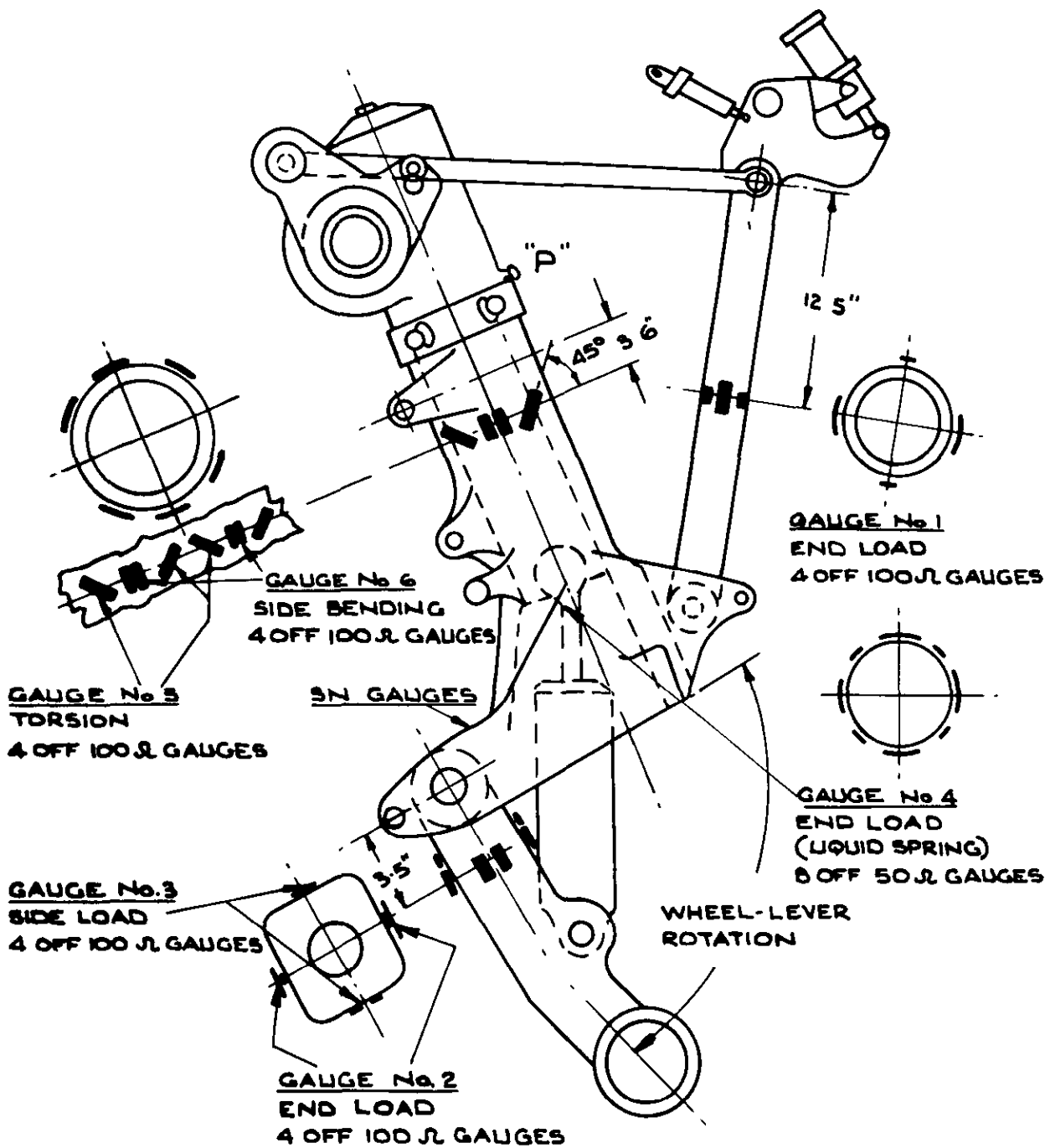

MEASUREMENT	
DEFLECTIONS	WHEEL LEVER ROTATION
PRESSURES	AT "P"

LOCATION OF STRAIN PRESSURE & DEFLECTION INSTRUMENTATION ON MAIN UNDERCARRIAGES.

FIG. 2.

12X 40415 579.01

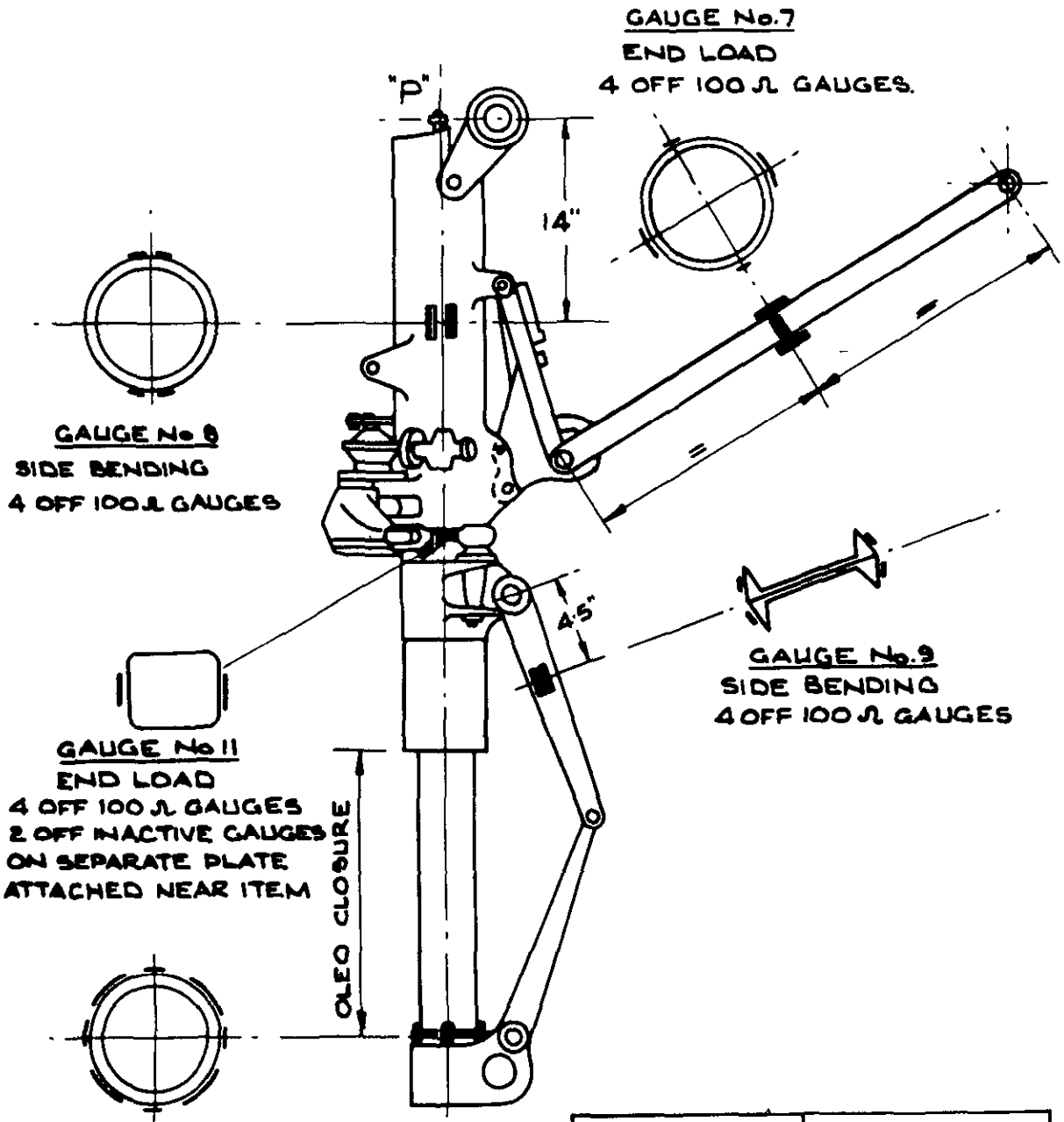

GAUGE No. 8
SIDE BENDING
4 OFF 100 Ω GAUGES

GAUGE No. 7
END LOAD
4 OFF 100 Ω GAUGES.

GAUGE No. 11
END LOAD
4 OFF 100 Ω GAUGES
2 OFF INACTIVE GAUGES
ON SEPARATE PLATE
ATTACHED NEAR ITEM

GAUGE No. 9
SIDE BENDING
4 OFF 100 Ω GAUGES

GAUGE No. 10
END LOAD
8 OFF 50 Ω GAUGES

MEASUREMENT	
DEFLECTIONS	OLEO CLOSURE, STEERING ANGLE
PRESSURES	AT "P"

LOCATION OF STRAIN PRESSURE & DEFLECTION INSTRUMENTATION ON NOSE UNDERCARRIAGE.

FIG 3

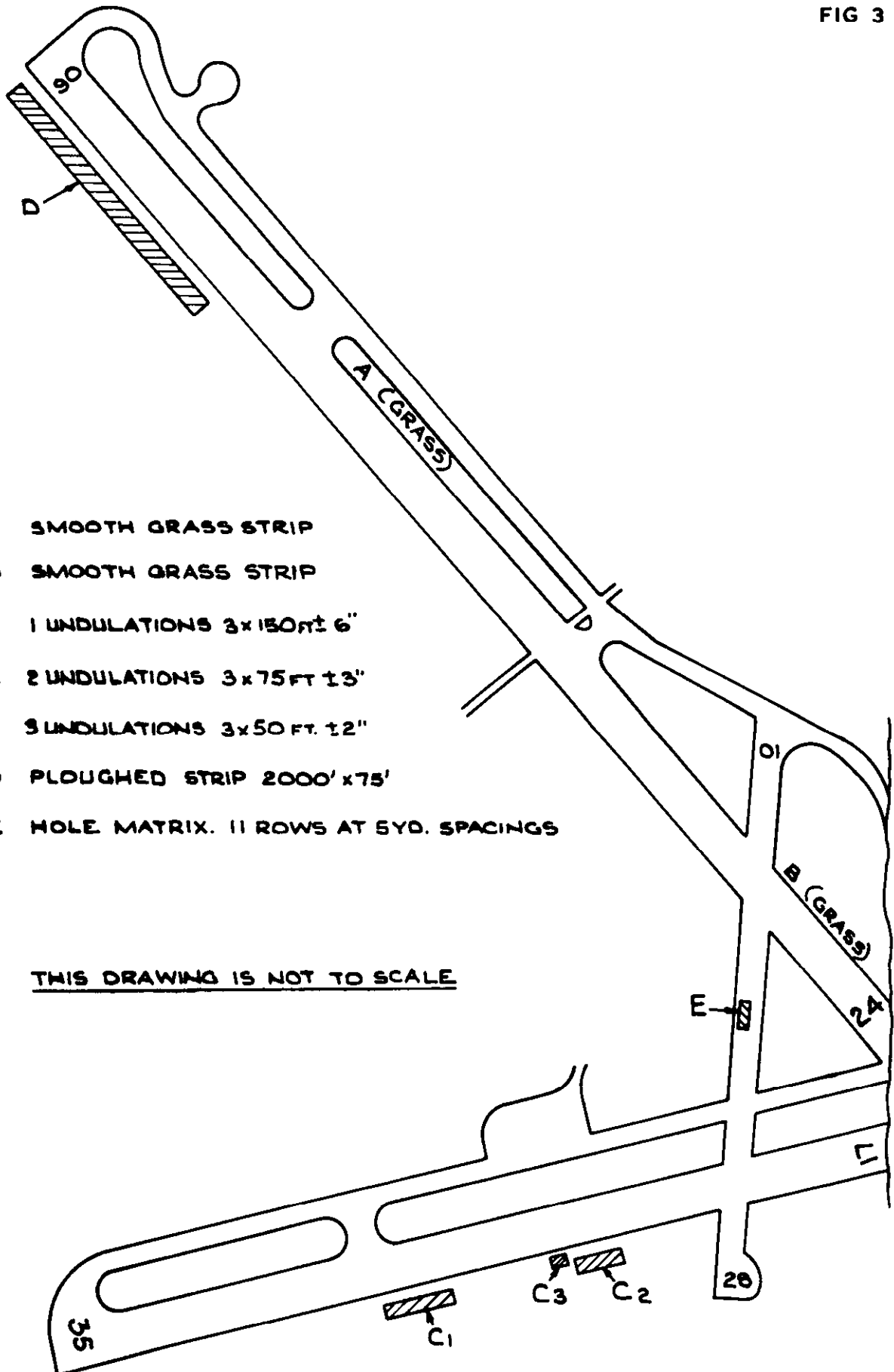

- A SMOOTH GRASS STRIP
- B SMOOTH GRASS STRIP
- C 1 UNDULATIONS 3x150 FT ± 6"
- C 2 UNDULATIONS 3x75 FT ± 3"
- C 3 UNDULATIONS 3x50 FT. ± 2"
- D PLOUGHED STRIP 2000' x 75'
- E HOLE MATRIX. 11 ROWS AT 5YD. SPACINGS

THIS DRAWING IS NOT TO SCALE

LOCATION OF TEST FACILITIES AT A. & A. E. E.

FIG 4.

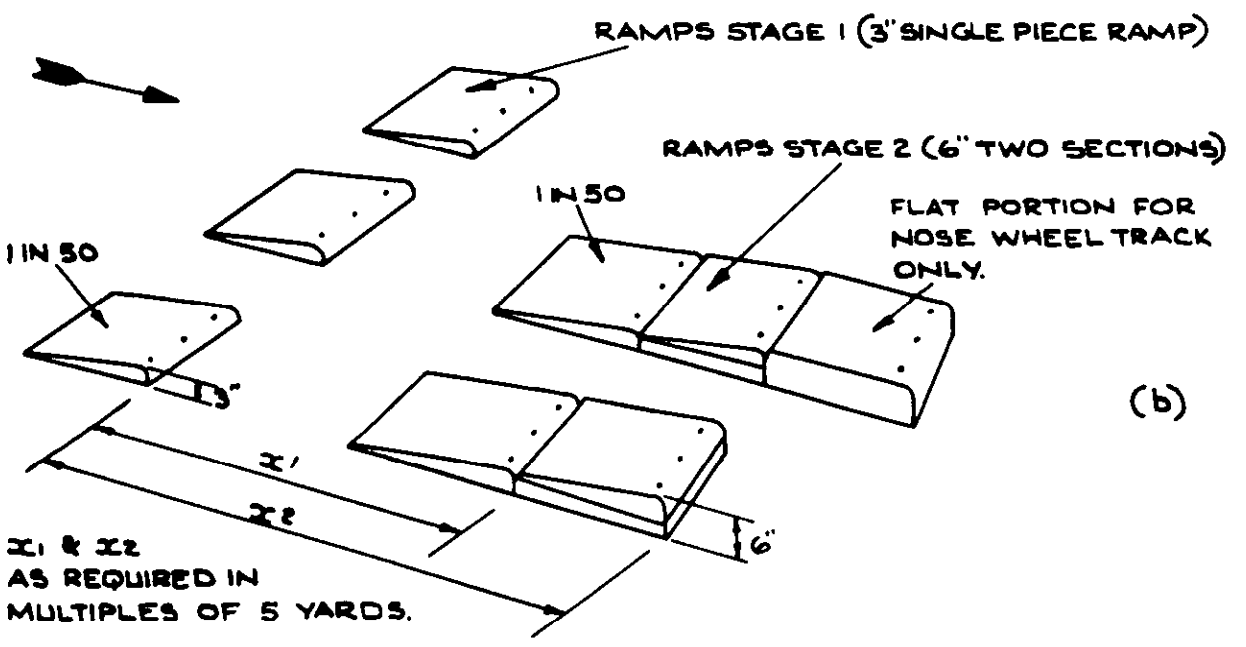
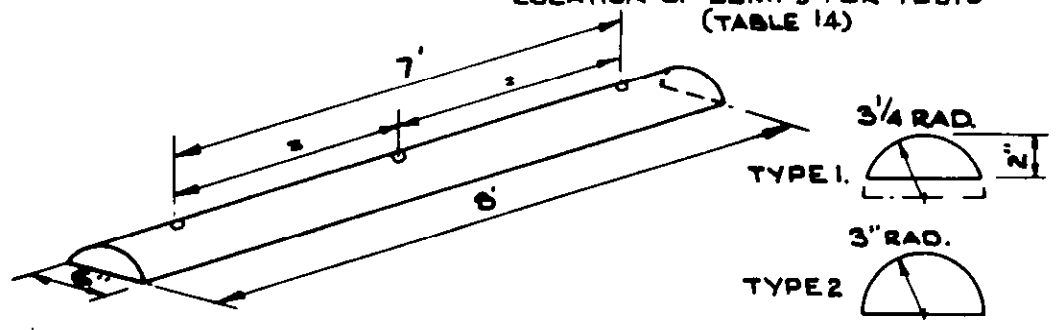
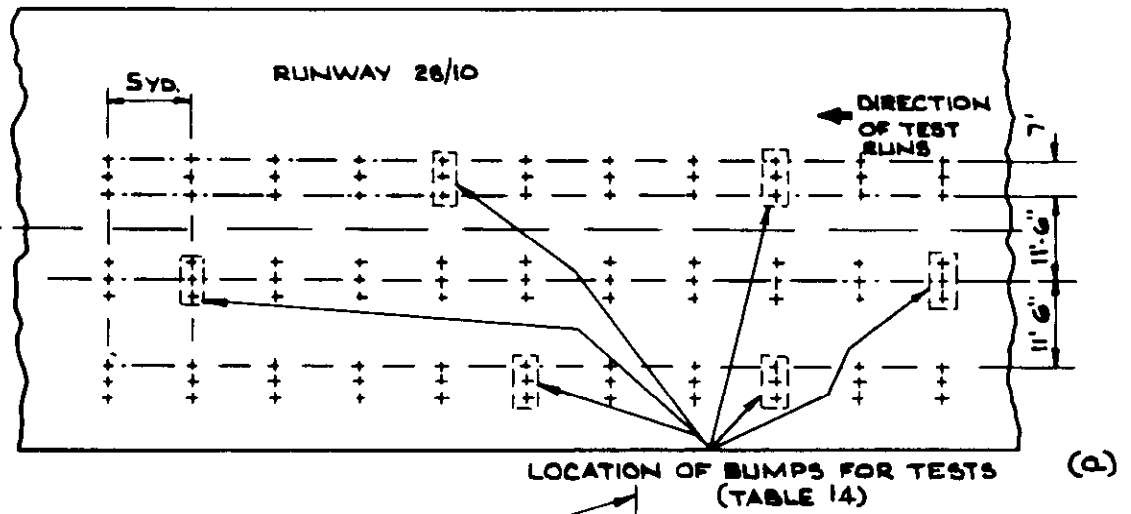

ARTIFICIAL BUMPS & RAMPS.

① ② ③ - RAF ANDOVER
 ④ - RAF ABINGDON
 ③ & ④ PRODUCED LIMITING NOSE GEAR LOADS BETWEEN 40 - 60 KT

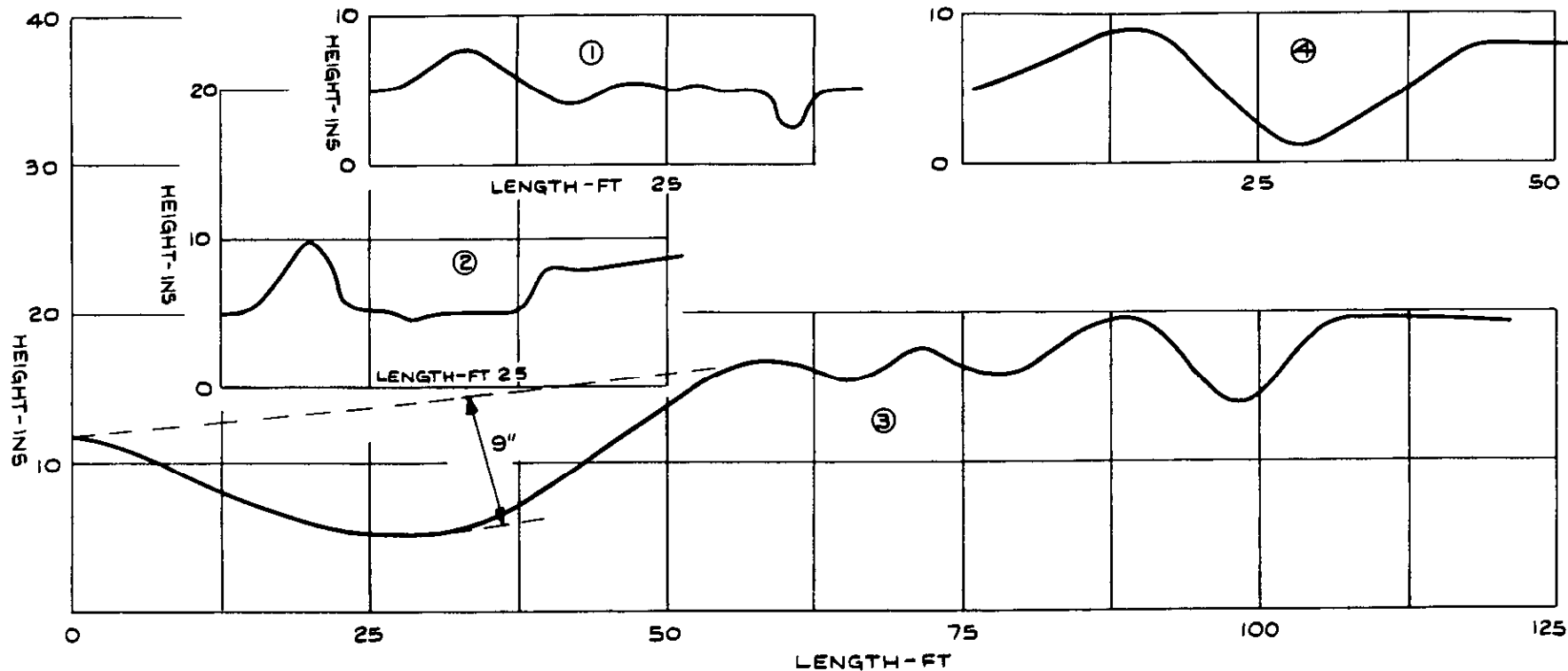

EXAMPLES OF NATURAL BUMPS MEASURED DURING ANDOVER C MK1 TRIALS.

FIG 6.

BOTH THESE SECTIONS OF TERRAIN
WERE ACCEPTABLE TO ANDOVER C.MK.I.

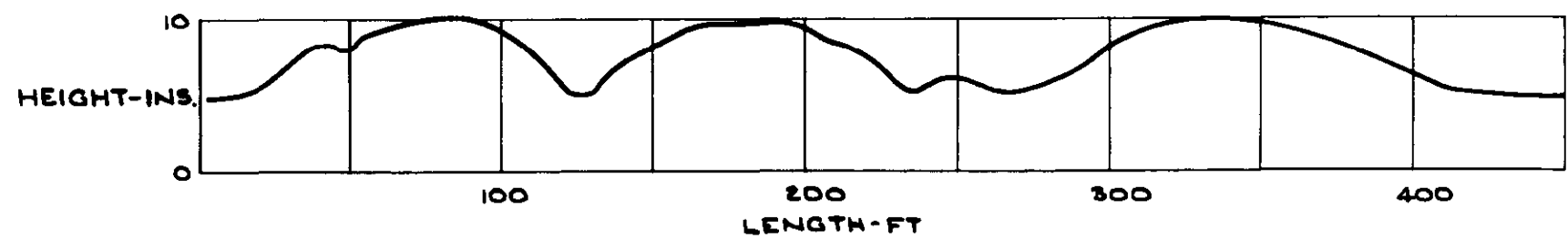
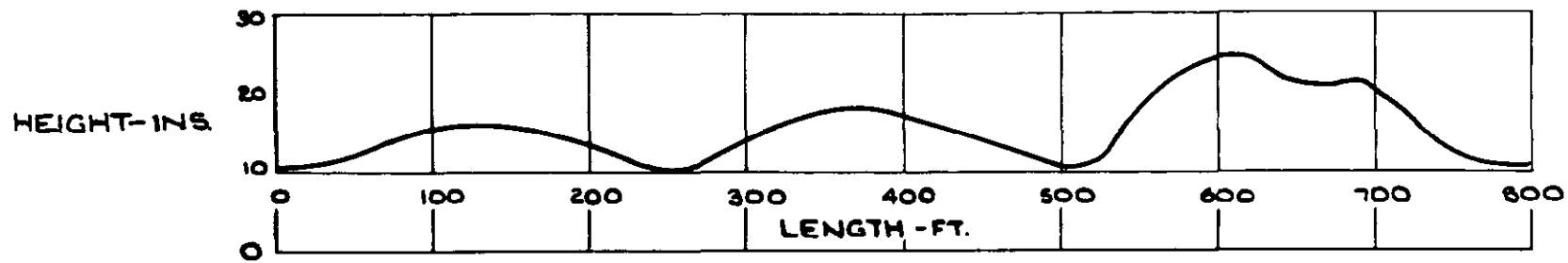

EXAMPLES OF NATURAL UNDULATIONS — R.A.F. ANDOVER.

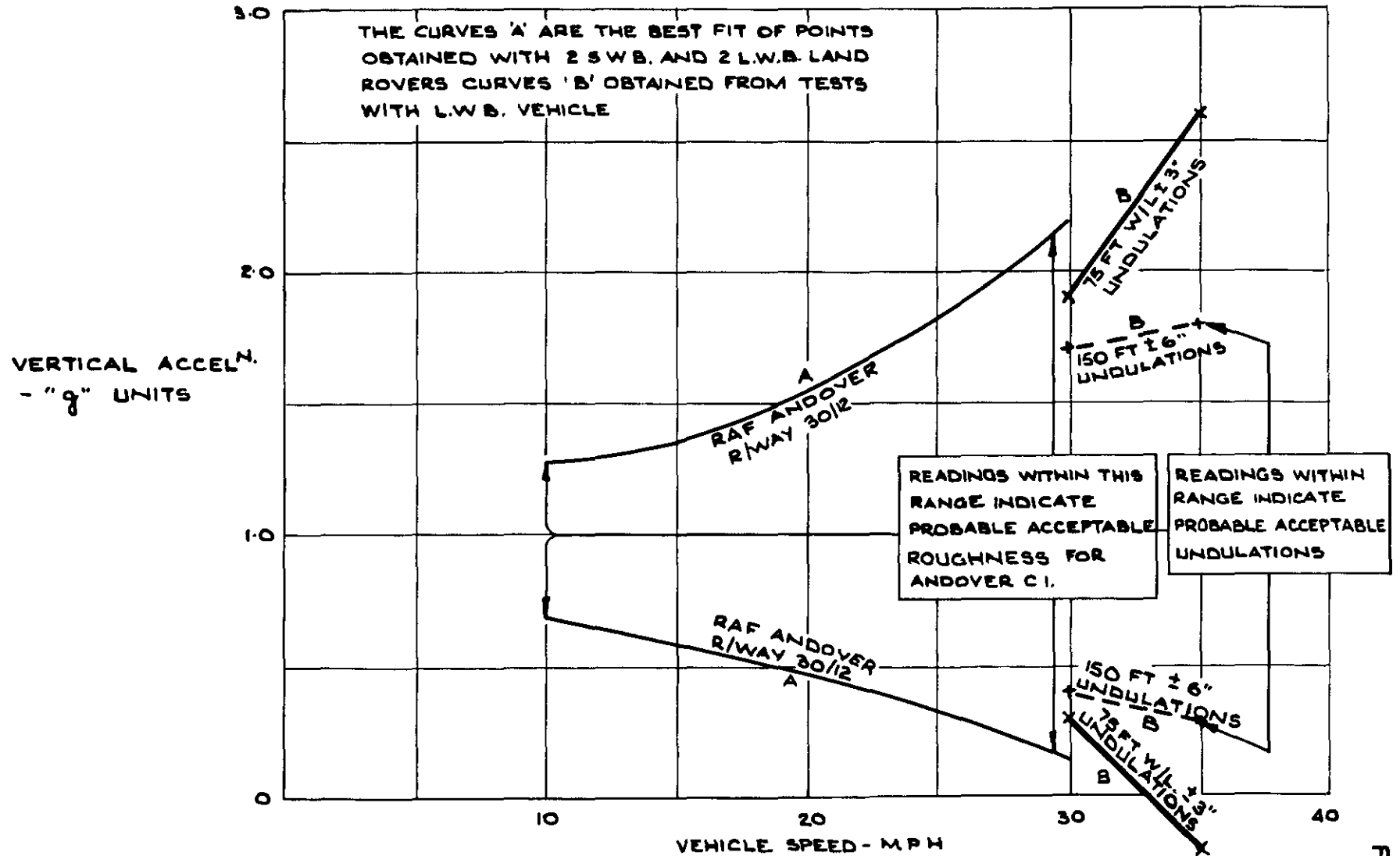

OPERATION FROM NATURAL OR SEMI- PREPARED SURFACES PEAK VERTICAL ACCELERATIONS.
ACCELEROMETER TYPE KB 482/01 IN LAND ROVER

FIG. 8.

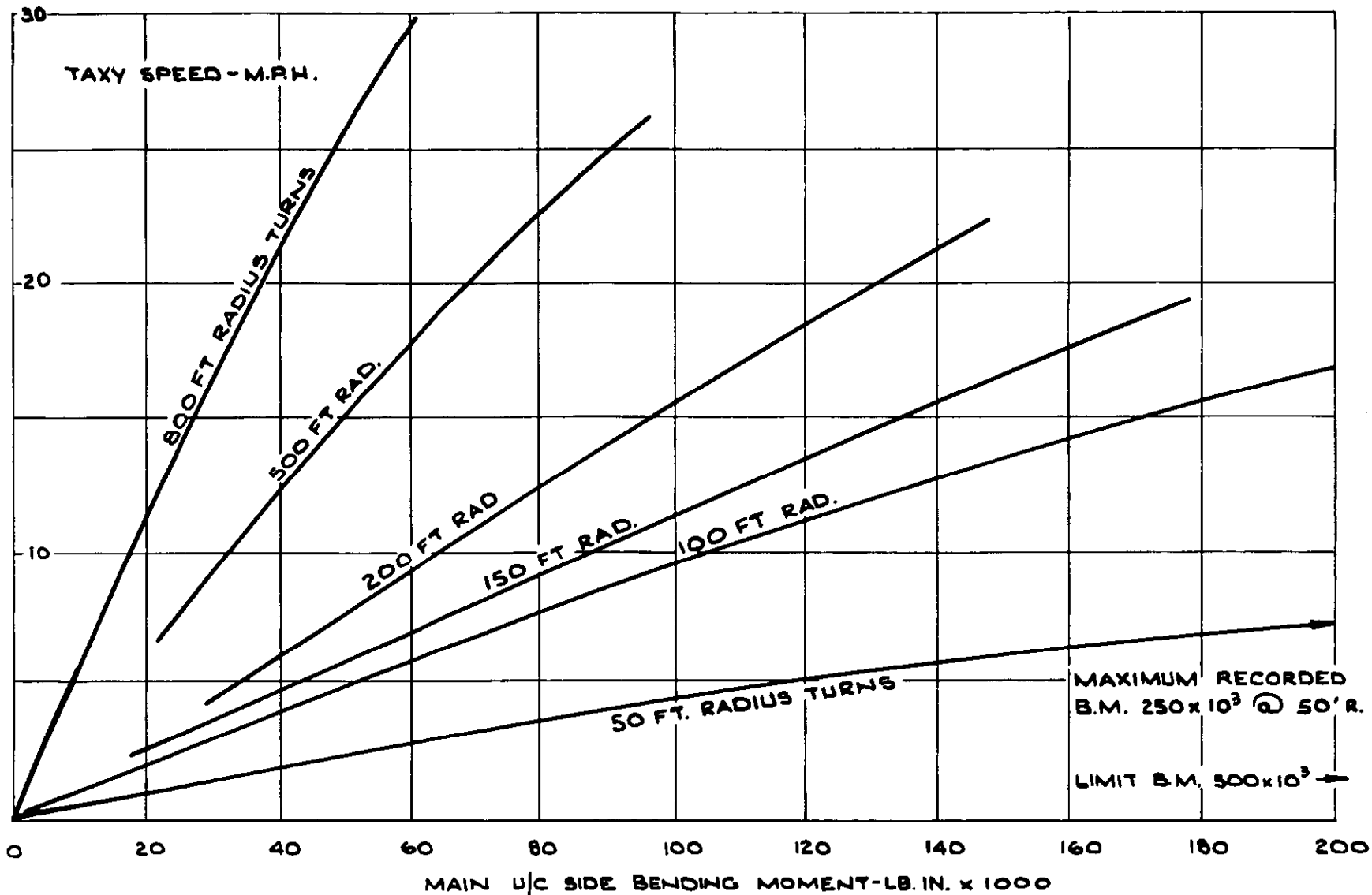

GROUND MANOEUVRING ENVELOPE.

FIG. 10.

COMPARISON OF NOSELEG CLOSURE WITH END LOAD.

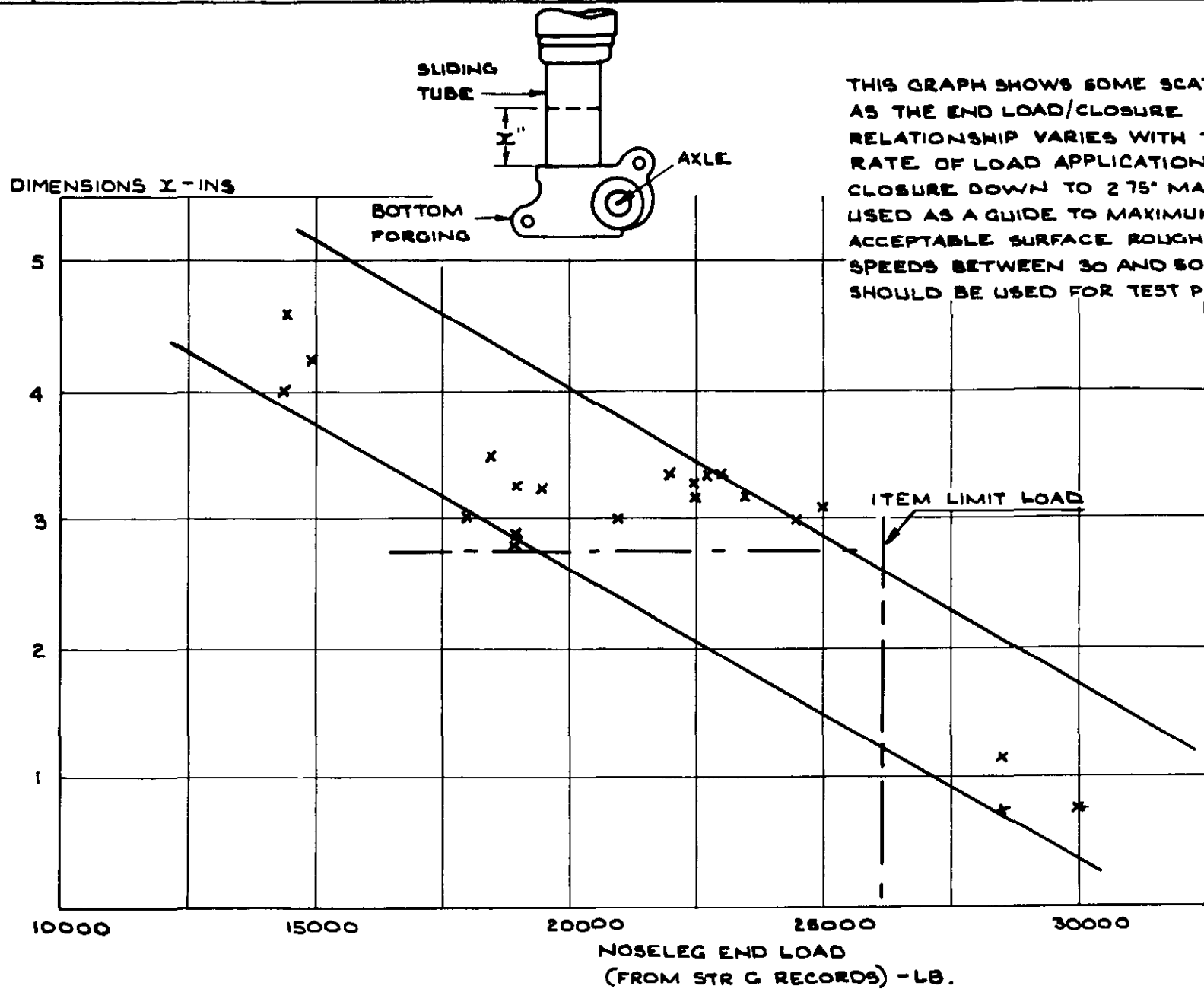
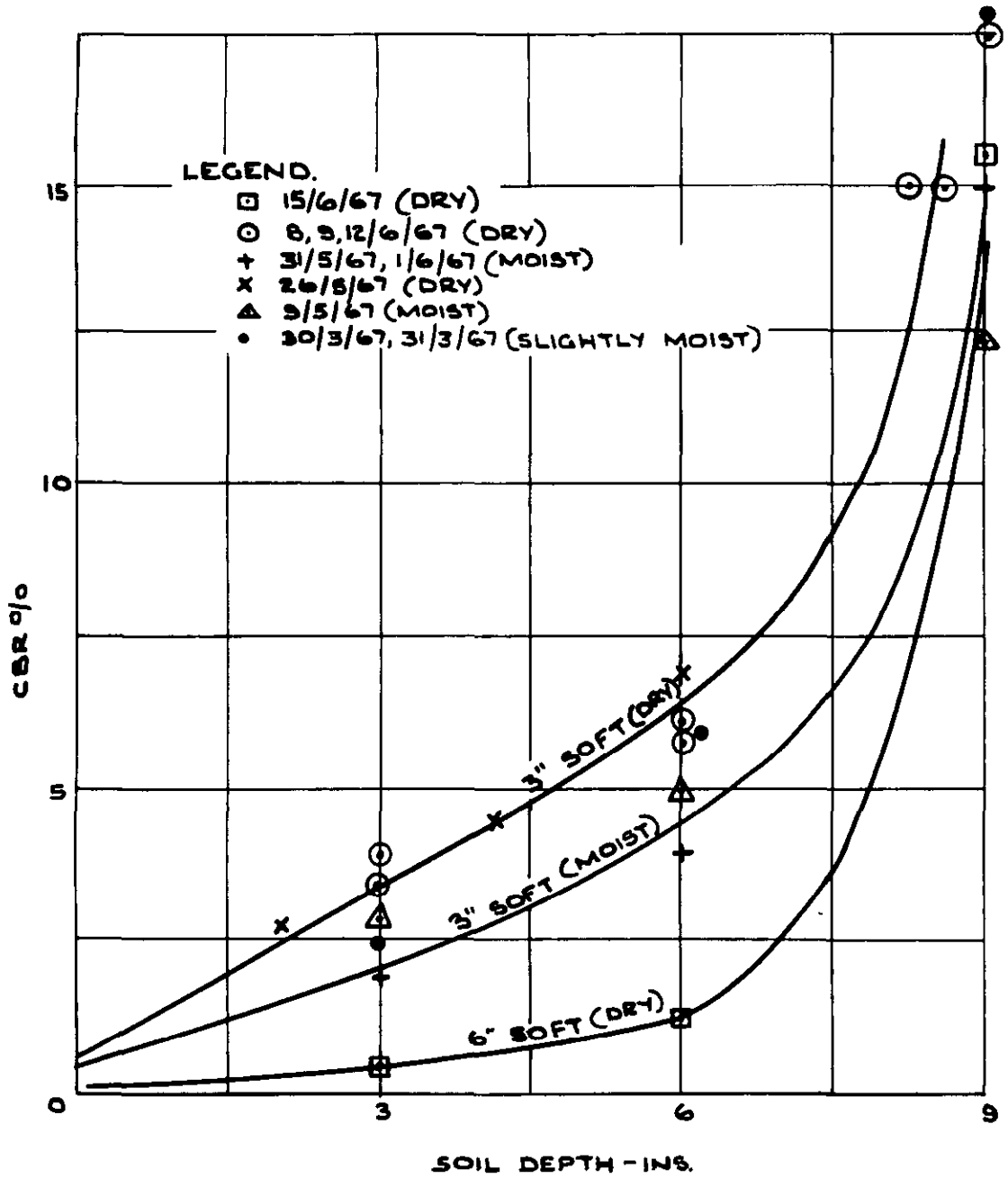
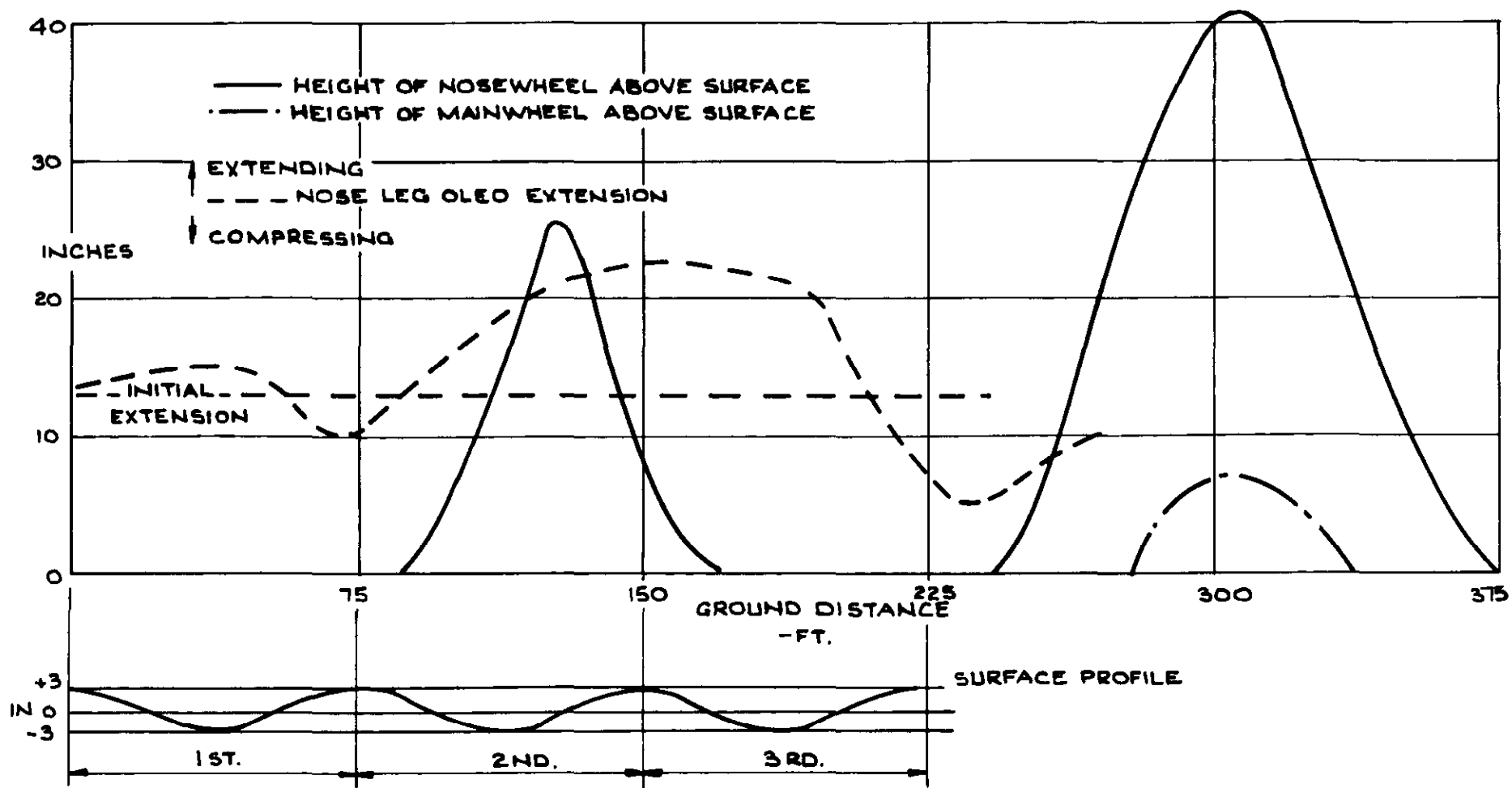

FIG 11.



SOFT SOIL TESTS ON A.&A E.E. PLOUGHED STRIP. MEAN C.B.R.



PITCHING ON 75 FT UNDULATIONS WHEN ACCELERATING THROUGH 44 KT.

FIG 32.

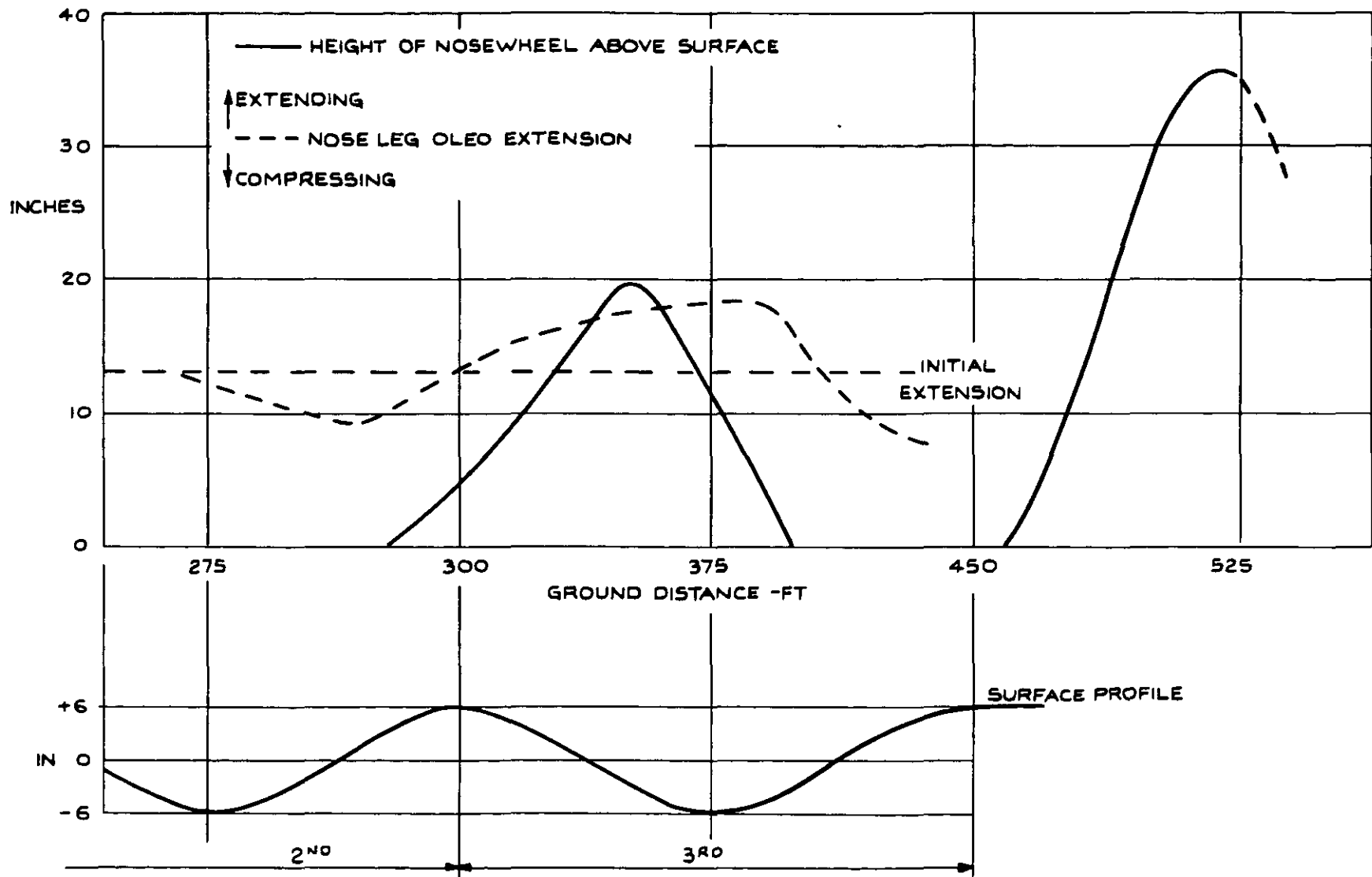

PITCHING ON 150 FT. UNDULATIONS WHEN ACCELERATING FROM 55-63 KT.

FIG. 33

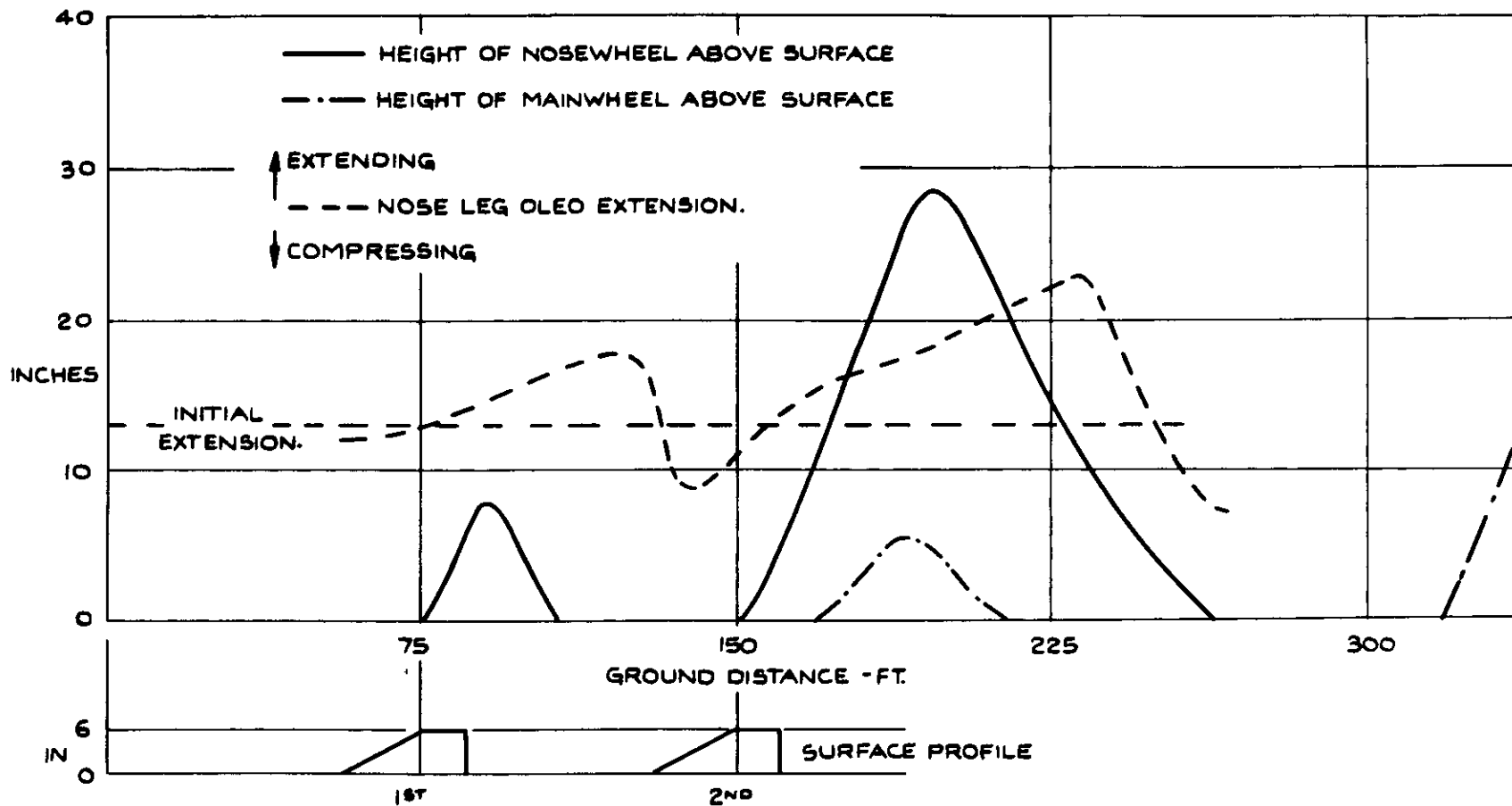

PITCHING ON 6 IN, 1 IN 50 RAMPS SPACED AT 75-FT ACCELERATING THROUGH 40 KT.
SIMULATION OF 75 FT. SINUSOIDAL UNDULATIONS.

FIG. 34

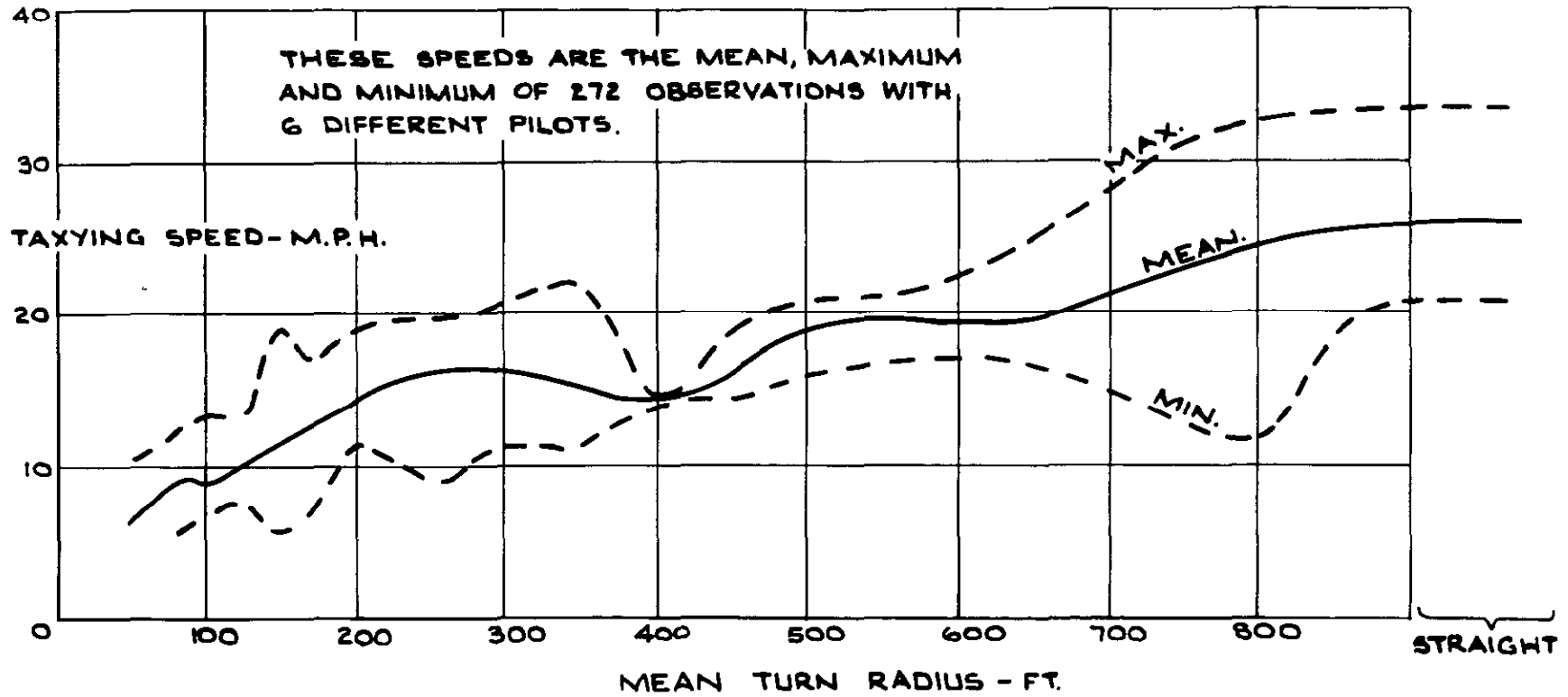

GROUND MANOEUVRING SPEEDS.

FIG 35

TEST POINTS - ⊗

- 1-4 3", 1 IN 50 RAMPS. - - - - - ACCEPTABLE
- 5 50 FT. ± 2" UNDULATIONS. - - - - - ACCEPTABLE
- 6 75 FT. ± 3" UND + 6", 1 IN 50 RAMPS. - UNACCEPTABLE.
- 7 150 FT ± 6" UND. - - - - - MARGINAL AT FWD. C.G.
UNACCEPTABLE AT AFT C.G.
- 8 R'WAY 30 AT RAF ANDOVER. - - - - - ACCEPTABLE
- 9 6" 1 IN 50 RAMPS. - - - - - ACCEPTABLE
- 10 R'WAY 30 AT RAF ANDOVER - - - - - ACCEPTABLE

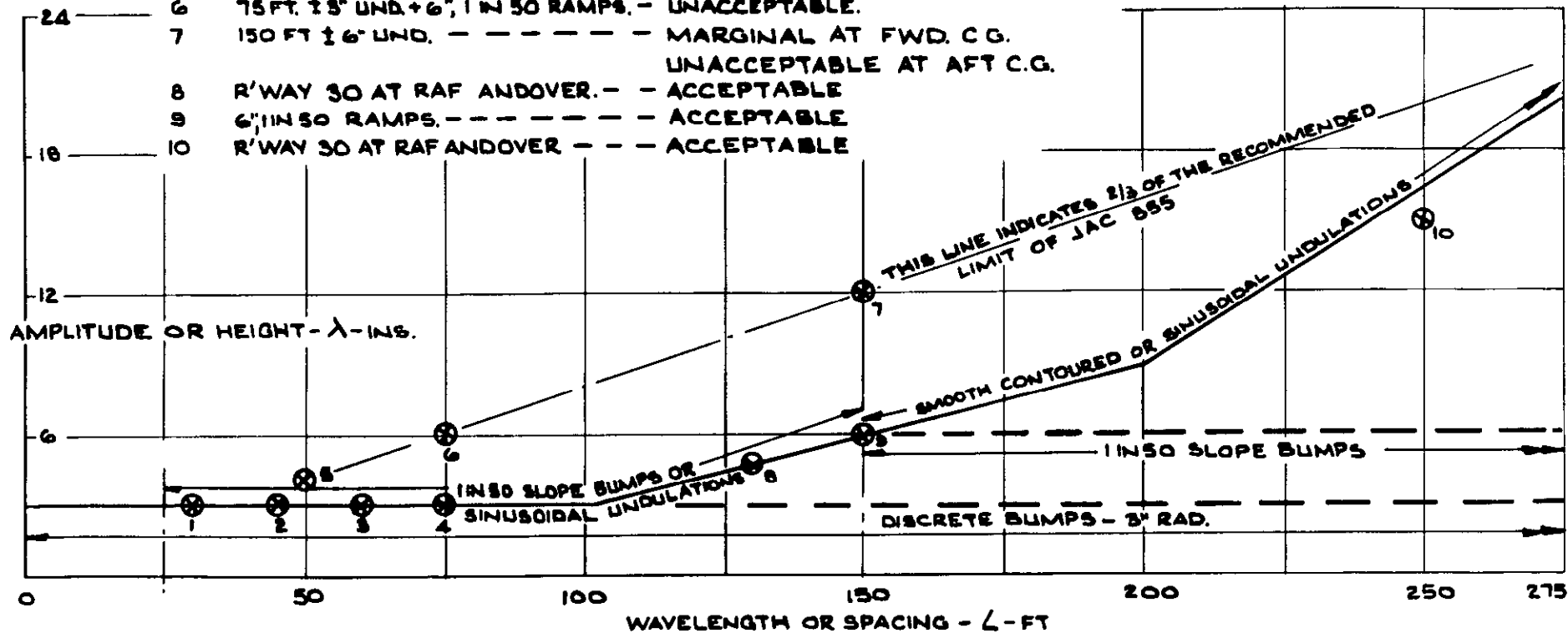

OPERATION FROM NATURAL OR SEMI - PREPARED SURFACES. SURFACE PROFILE ENVELOPE.

FIG. 36.

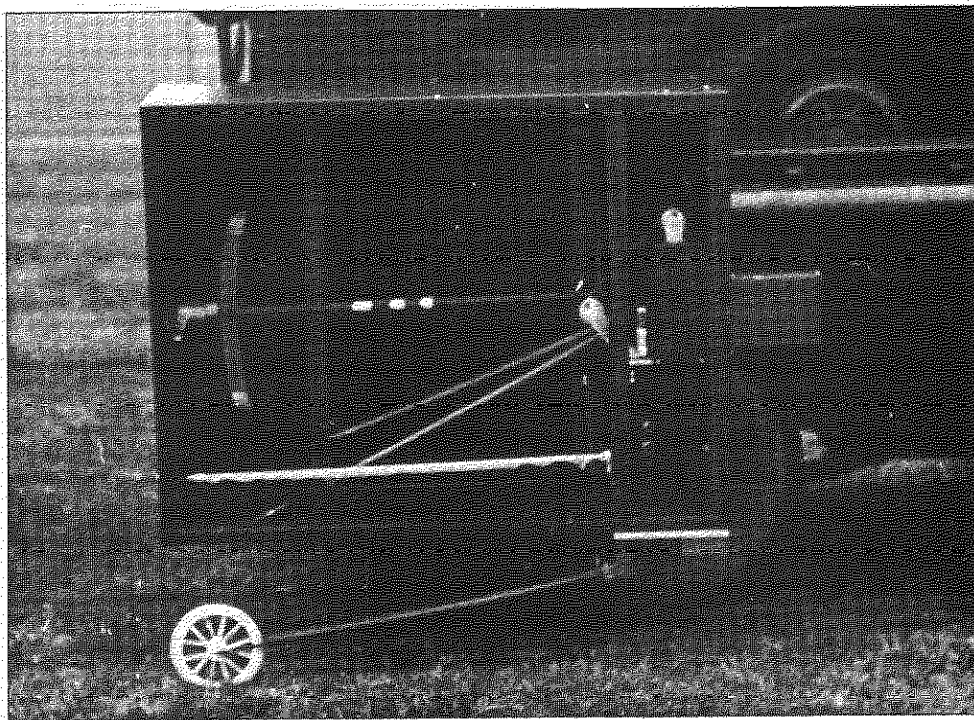

FIG. 1. M.E.X.E. PROFILOMETER MOUNTED ON L.W.B. LAND ROVER.
(COVER PLATE REMOVED).

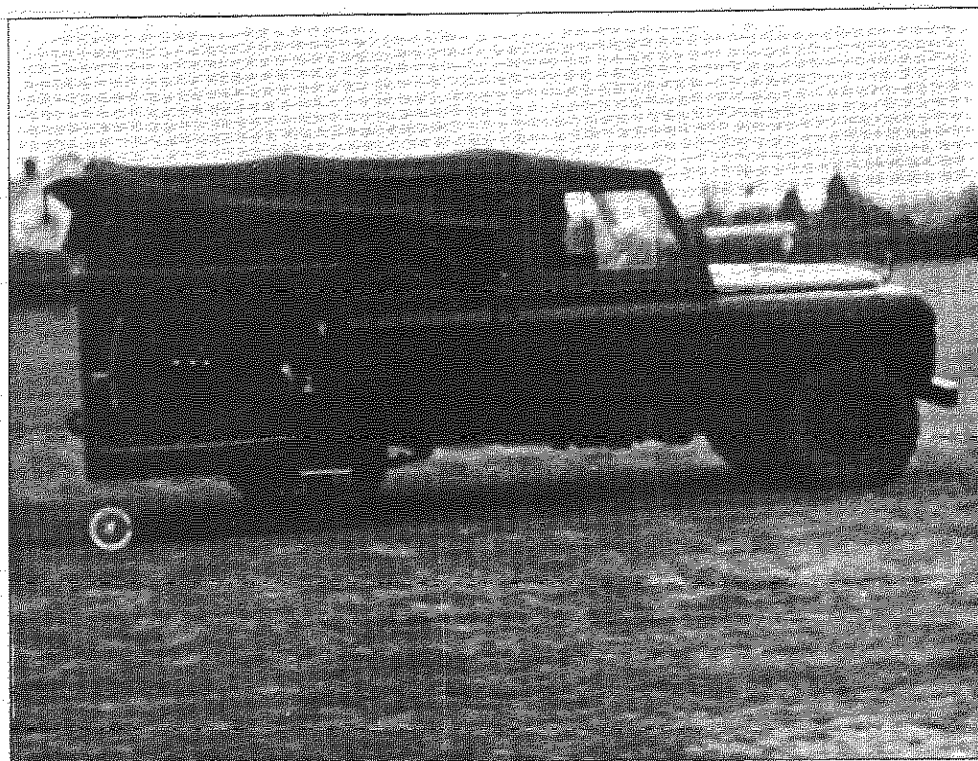

FIG. 2. LAND ROVER WITH PROFILOMETER TRAVERSING ROUGH GRASS.

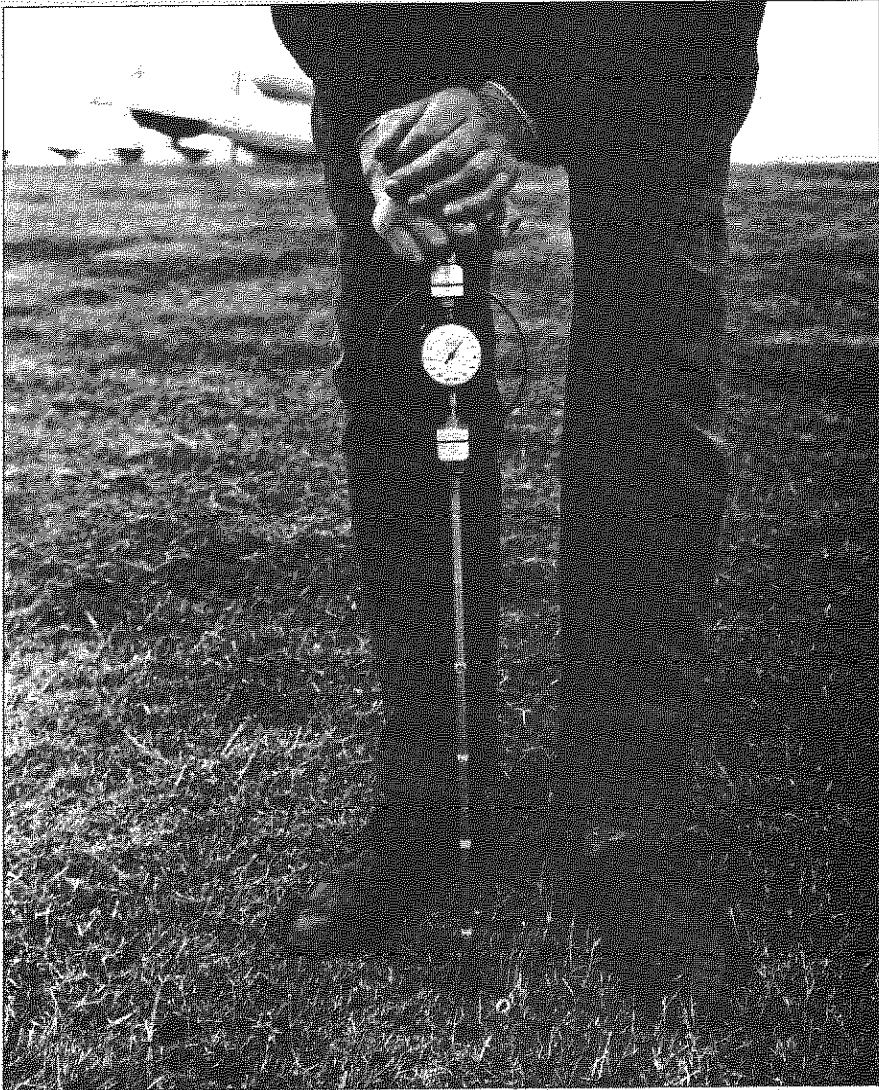

FIG. 5. M.E.X.E. CONE PENETROMETER.



FIG. 9. PLOUGHED LANDING STRIP AT A. & A.E.E.
GENERAL SIZE OF FLINTS COMPARED WITH WHEEL TRACK.

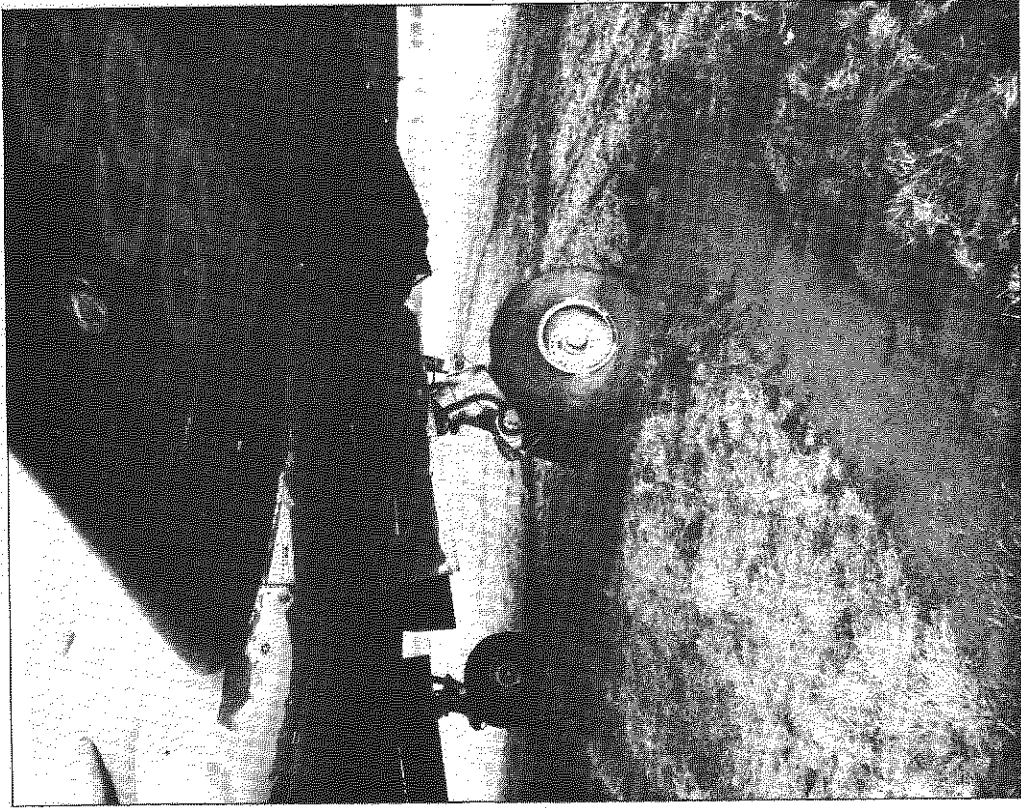

FIG. 13. WET GRASS. ILLUSTRATION OF PEELING OF TURF WITH TENDENCY TO SKIDDING IN TURNS.

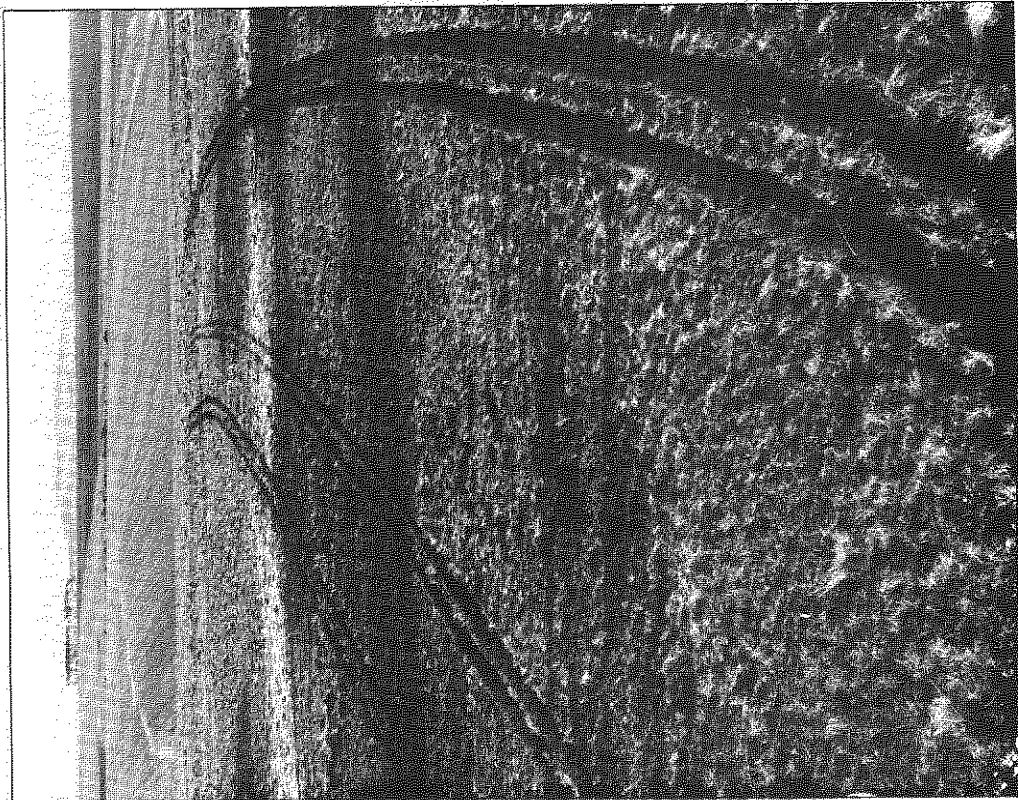

FIG. 12. WET GRASS. RUTTING IN TURNS.

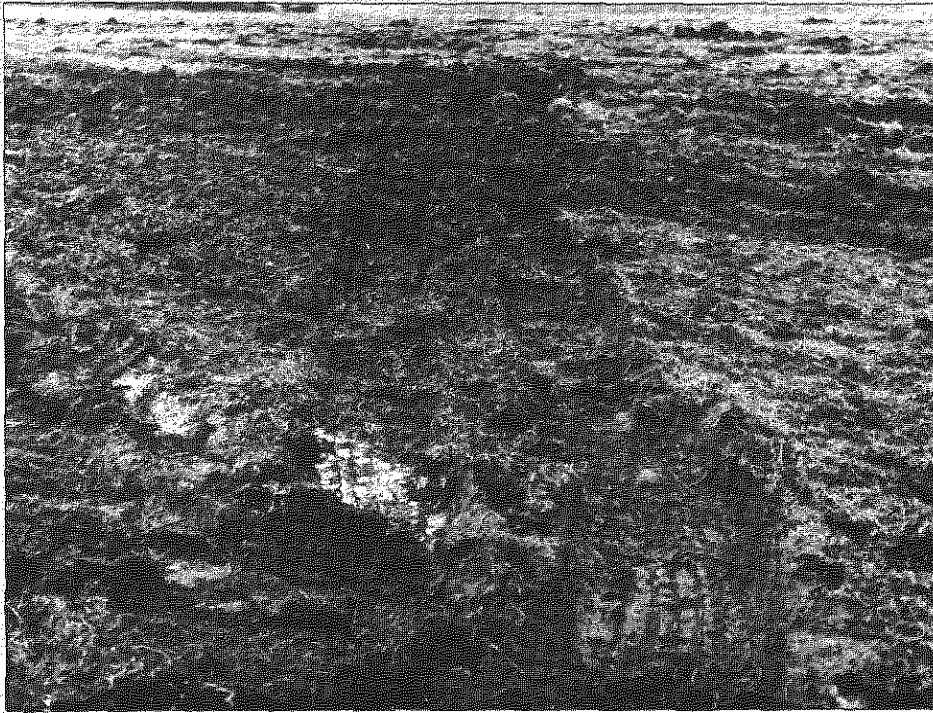

FIG. 14. UPAVON GALLOPS. SOIL TEXTURE IN WET, MUDDY AREAS.



FIG. 15. UPAVON GALLOPS. TEXTURE OF WET, FIBROUS SOIL AREAS.

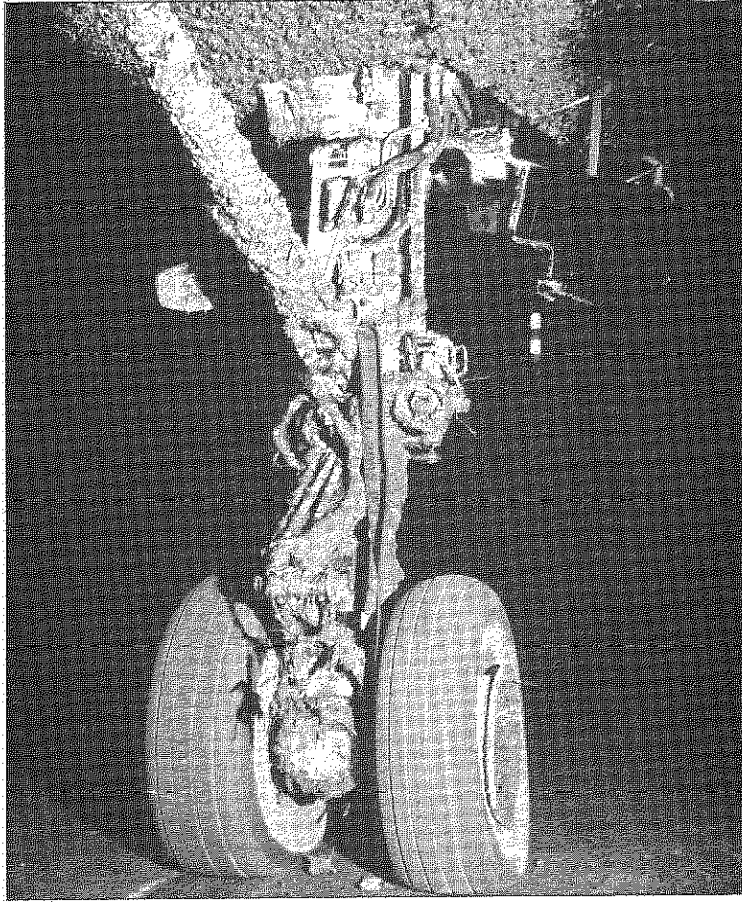

FIG. 16. AIRCRAFT CONTAMINATION BY SOFT MUD.
NOSE UNDERCARRIAGE.

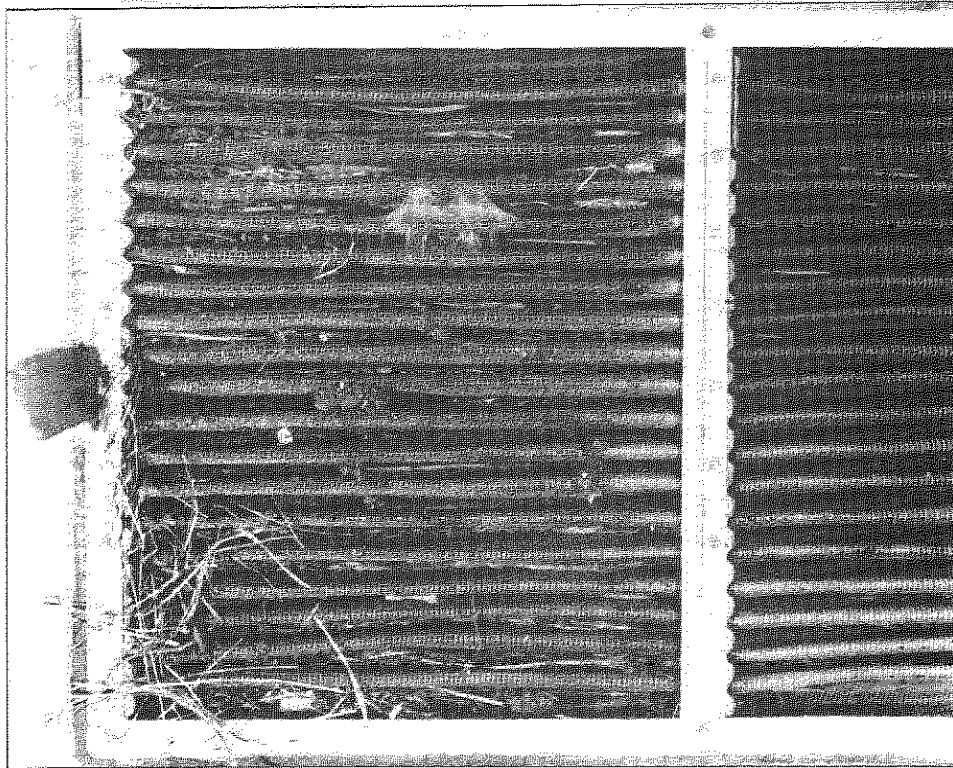

FIG. 17. AIRCRAFT CONTAMINATION. CABIN BLOWER INTAKE
FILTER AFTER 3 MOVEMENTS ON MUDDY GRASS.

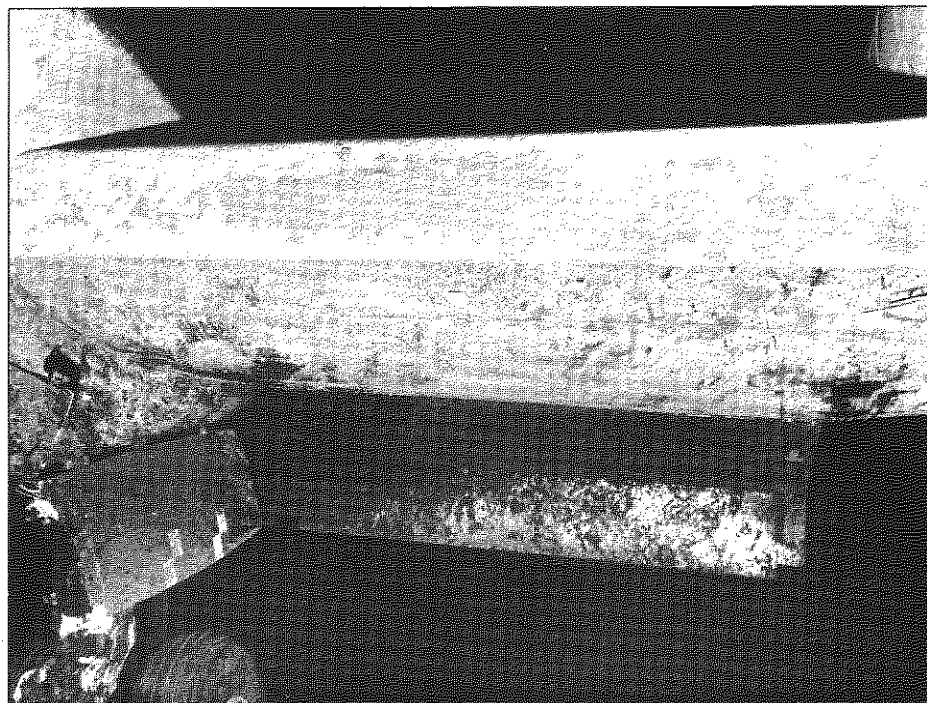

FIG. 18. AIRCRAFT CONTAMINATION. MUD ON LEADING EDGE, STARBOARD NACELLE AND UNDERCARRIAGE DOORS AND FLAPS.

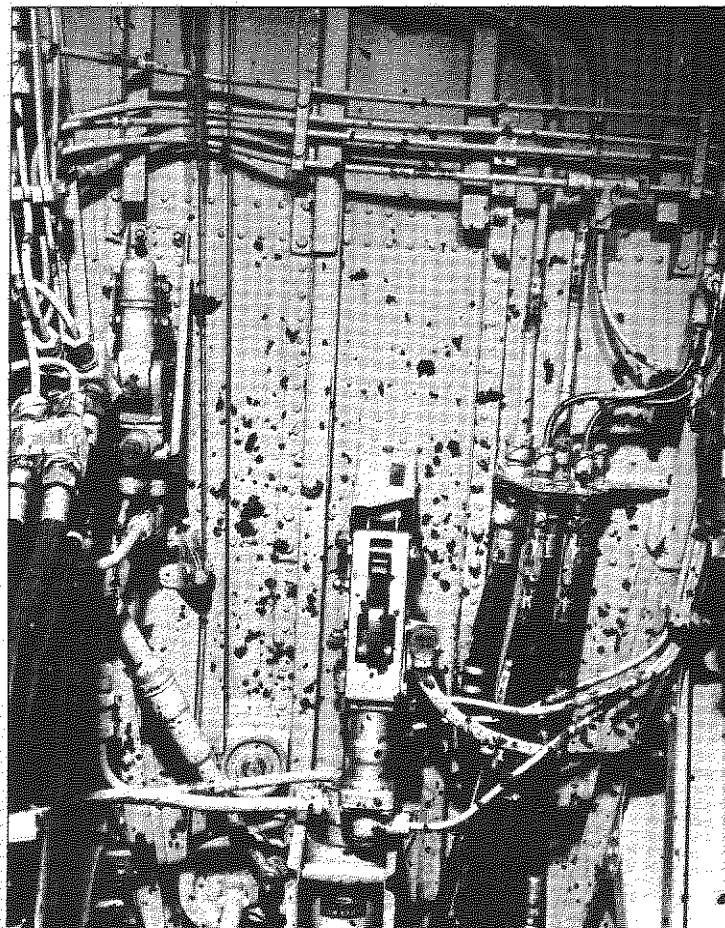

FIG. 19. AIRCRAFT CONTAMINATION. MUD IN VICINITY OF NOSE UNDERCARRIAGE UP LOCK.



FIG. 20. CONTAMINATION IN MAIN UNDERCARRIAGE BAY.

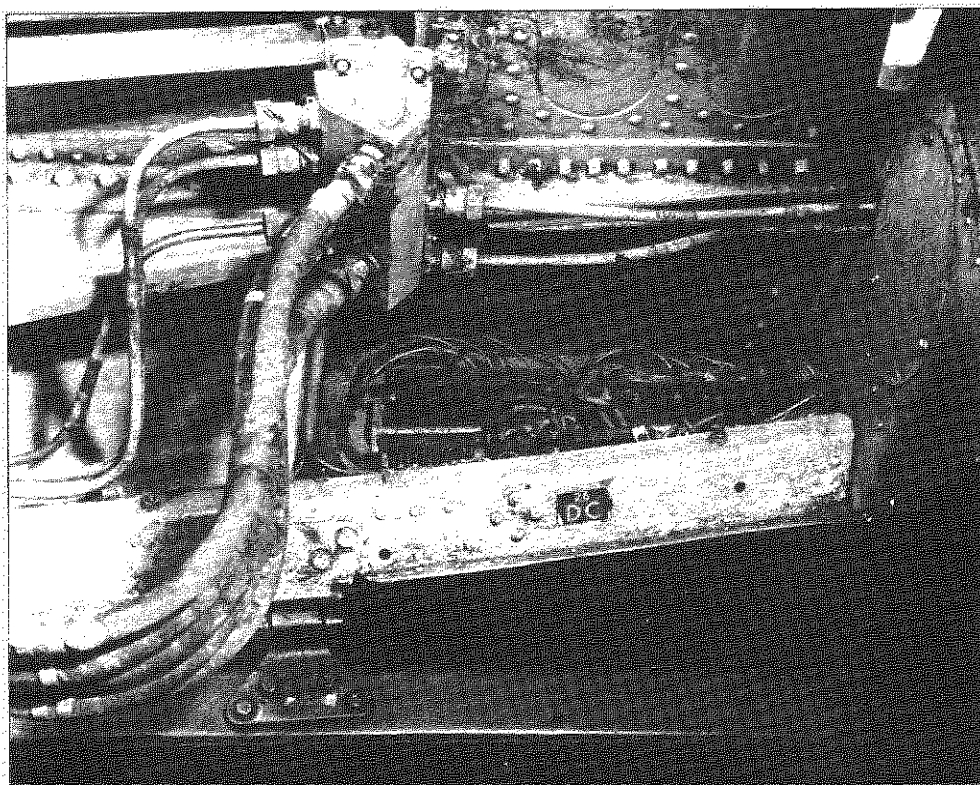

FIG. 21. CONTAMINATION OF ELECTRICS IN MAIN WHEEL BAY.



FIG. 22. CONTAMINATION OF FLAP TRACKS.

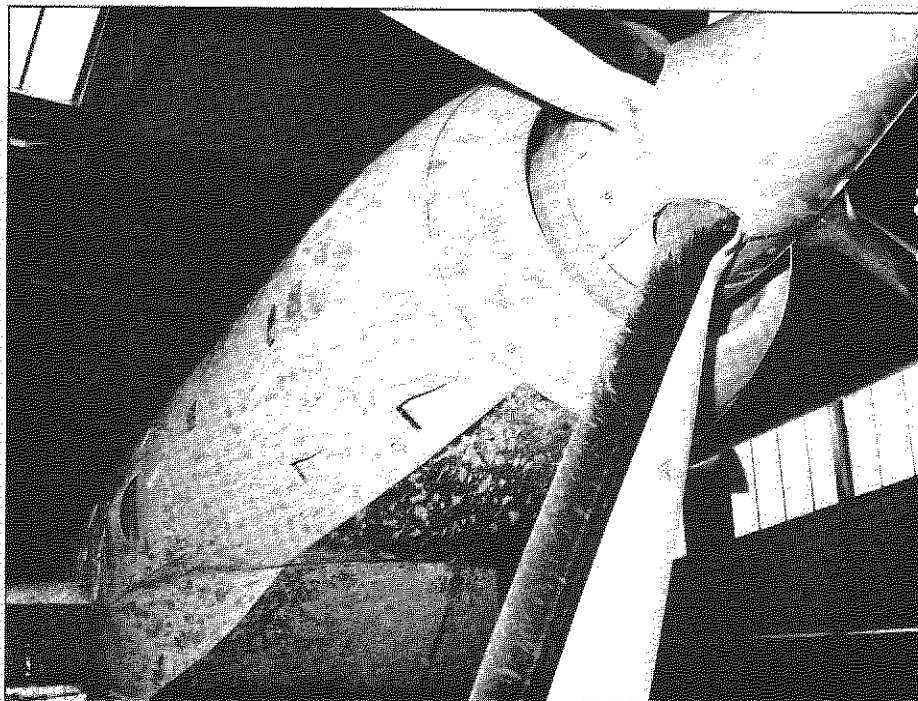

FIG. 23. CONTAMINATION OF NACELLE, INTAKE LIP AND PROPELLOR,
SUGGESTING DEBRIS INGESTION.

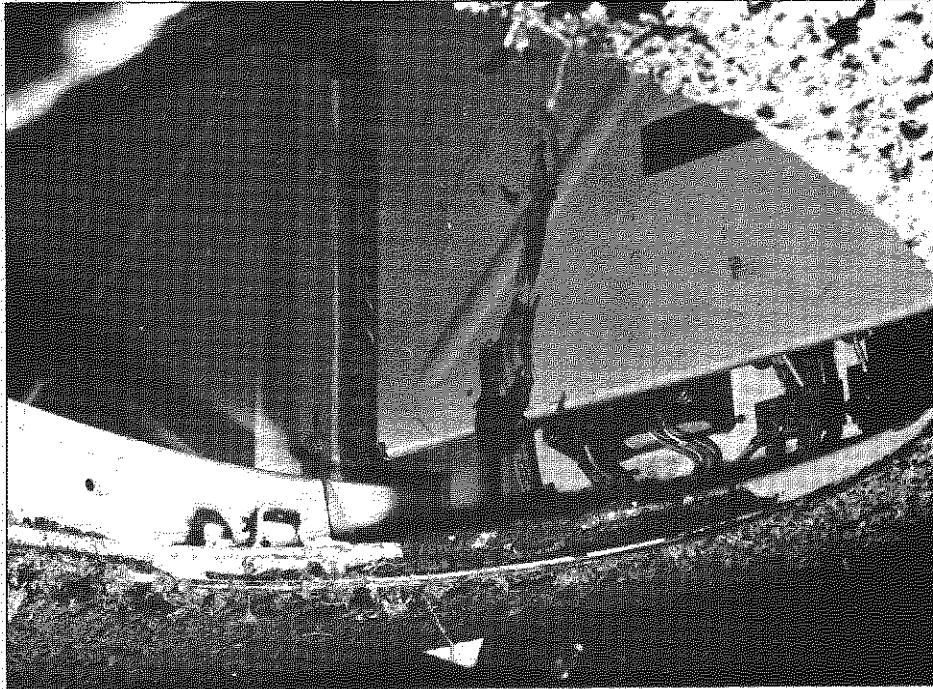

FIG. 24. PENETRATION OF DEBRIS THROUGH LOWER HATCH SEALS.

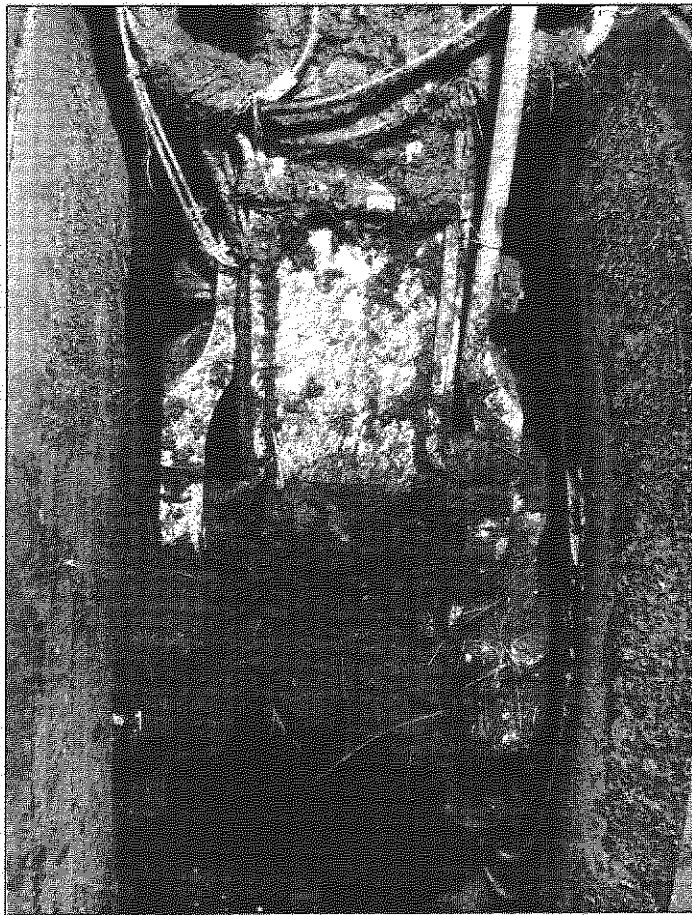

FIG. 25.

PACKING OF SOIL IN AND BETWEEN THE MAIN WHEELS.

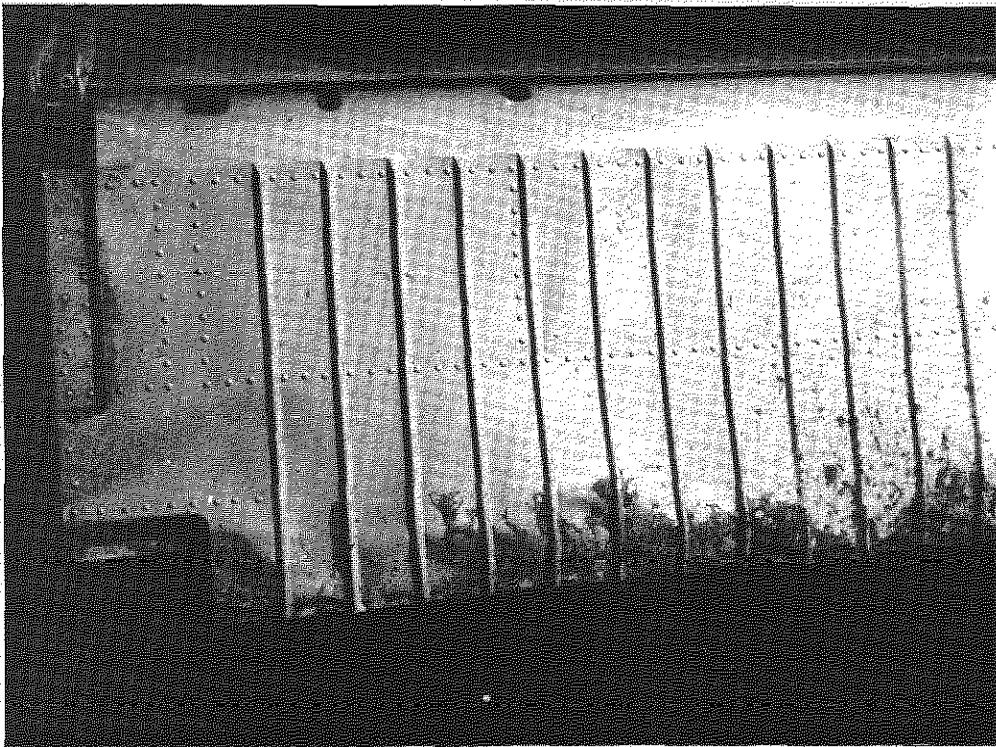

FIG. 26. FLAP TAB DAMAGE, CAUSED BY FLYING SOIL.



FIG. 28. A. & A.E.E. SOFT EARTH STRIP. RUTTING WITH SURFACE LAYER SOFTENED TO 3 INCHES.



FIG. 29. A. & A.E.E. SOFT EARTH STRIP. RUTTING IN TURNING AREA. 2 INCH WET SOIL ON FROZEN SUBGRADE.

A. & A.E.E. 17283.

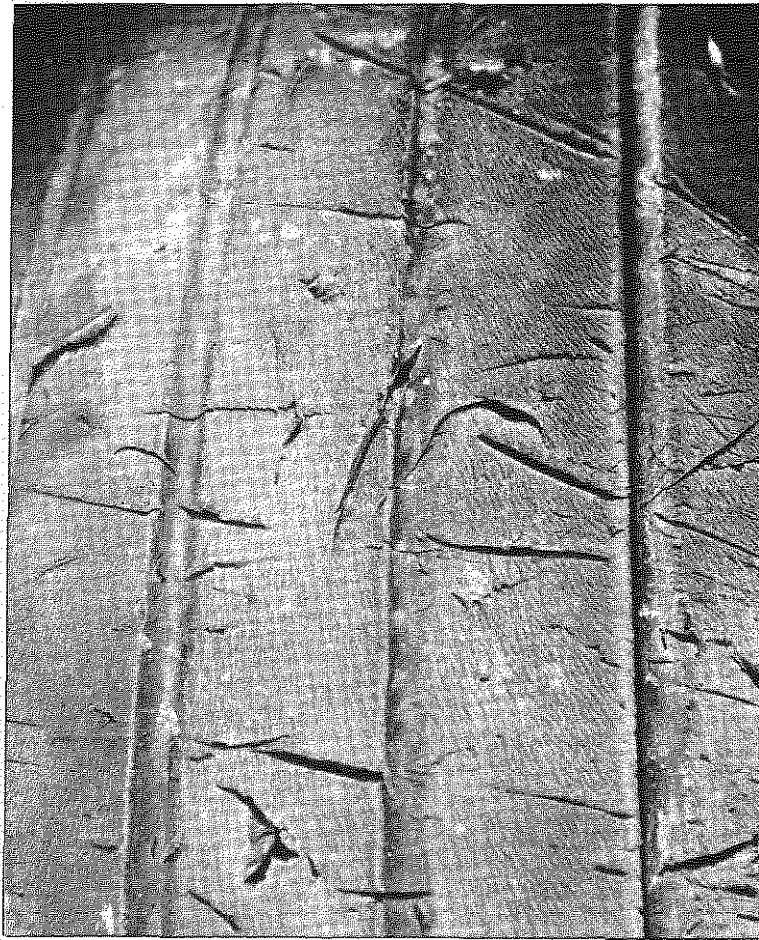

FIG. 30. TYPICAL TYRE DAMAGE FROM SHARP STONES
IN A. & A.E.E. SOFT EARTH STRIP.

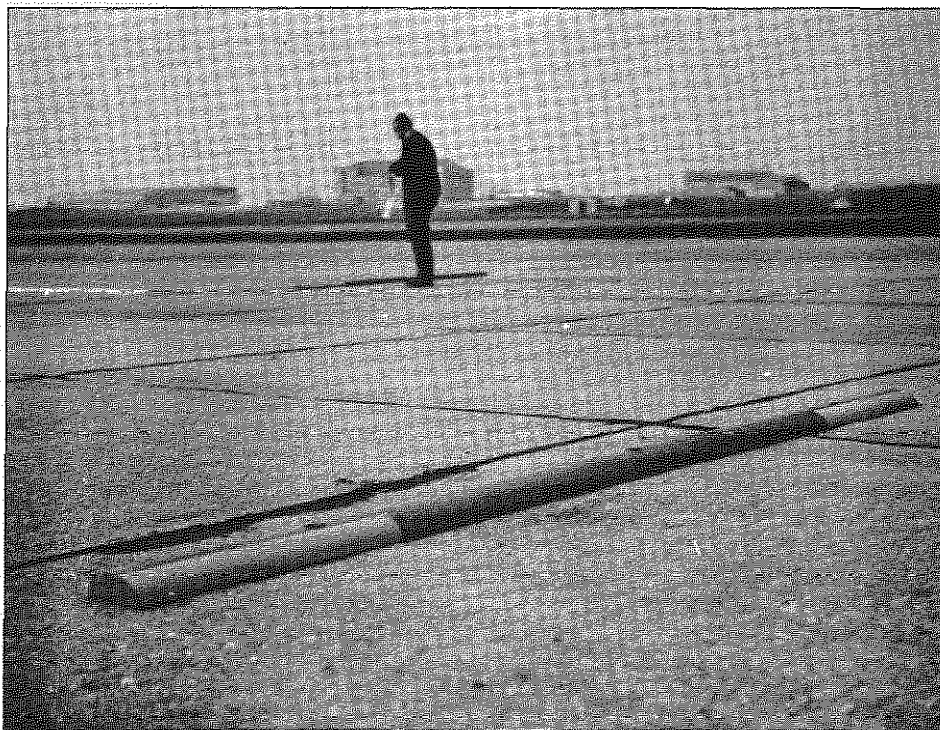

FIG. 31. SIMULATED 3 INCH BUMPS.



FIG. 37. TYPICAL PROPELLOR BLADE DAMAGE AFTER BLENDING,
FOLLOWING 60 MOVEMENTS ON A STONY SURFACE.

© Crown copyright 1972

HER MAJESTY'S STATIONERY OFFICE

Government Bookshops

49 High Holborn, London WC1V 6HB

13a Castle Street, Edinburgh EH2 3AR

109 St Mary Street, Cardiff CF1 1JW

Brazennose Street, Manchester M60 8AS

50 Fairfax Street, Bristol BS1 3DE

258 Broad Street, Birmingham B1 2HE

80 Chichester Street, Belfast BT1 4JY

*Government publications are also available
through booksellers*