

C.P. No. 532

ROYAL CANADIAN MOUNTED POLICE  
RED CROSS

C.P. No. 532



MINISTRY OF AVIATION

AERONAUTICAL RESEARCH COUNCIL

CURRENT PAPERS

# Automatic Control of Laboratory Representation of Kinetic Heating

*by*

*J. Taylor*

LONDON: HER MAJESTY'S STATIONERY OFFICE

1961

PRICE 3s. 6d. NET



July, 1960

AUTOMATIC CONTROL OF LABORATORY REPRESENTATION  
OF KINETIC HEATING

by

J. Taylor

---

SUMMARY

The purpose of the control system is to heat an aircraft structure by electrical power in the laboratory in a manner representative of the heating it receives in flight from its motion through the air.

The main characteristic of the control equipment is that it is entirely in digital form. The structural surface is divided into a number of discrete areas and each area is controlled separately. The basic aerodynamic data is presented in digital form at discrete time intervals to a computer. The computer also receives in digits the measured temperature of representative points of the structural surface and of the laboratory. The computer calculates the required quantity of heat and subtracts from it the measured heat being supplied at that moment. This figure is passed to a controller, which then ensures that the heating elements just achieve the new electrical power level in the prescribed unit of time. The whole process is then repeated continuously.

Since the time required by the digital computer to make its calculations is small compared with a unit time interval, the computer and many of the digitising processes are used on a time-sharing basis for up to 60 separate controllers.

## LIST OF CONTENTS

	<u>Page</u>
1 INTRODUCTION	3
2 LABORATORY REPRESENTATION OF KINETIC HEATING	3
2.1 Digital procedure	4
3 METHODS OF DIGITISING	5
3.1 Surface areas	5
3.2 Pre-calculated data	5
3.3 Measured data	6
3.4 Power	7
3.5 Time	7
4 CONTROL SYSTEM	7
4.1 Digital computer	7
4.2 Time sharing	8
4.3 Accuracy of a 1 second time cycle	9
5 THE COMPLETE APPARATUS	9

LIST OF SYMBOLS 10

ILLUSTRATIONS - Figs.1-10 -

DETACHABLE ABSTRACT CARDS -

### LIST OF ILLUSTRATIONS

	<u>Fig.</u>
Initial heating rate	1
Ultimate equilibrium temperature	2
Digital procedure of control	3
Time sharing of the control system	4
Error in heating and surface temperature of shell	5
Film reader for pre-calculated data	6
Control room	7
Power house showing 2 cabinets each containing 3 power regulators of 50 KW continuous rating	8
Close up of power regulator	9
Heating tests on cylinder with heater reflector removed	10

## 1 INTRODUCTION

The passage of a body through the atmosphere at high supersonic speed causes an appreciable temperature rise in the air in the immediate vicinity. If there is in consequence a temperature difference between the air and the body surface, heat will flow from one to the other, the process being known as kinetic heating. Since the rise in air temperature tends to be roughly proportional to the square of the speed, the thermal effects upon the structure rapidly assume importance as the operating speeds of aircraft and projectiles are increased. It has long been common practice to confirm by test the strength of complete aircraft structures. For high speed supersonic aircraft it is now becoming essential to include in such tests the effects of kinetic heating.

## 2 LABORATORY REPRESENTATION OF KINETIC HEATING

Quite irrespective of speed, if a structure and the air adjacent to it are at a different temperature, heat will flow from one to the other. It is convenient to regard the heat flow as the product of temperature difference and a heat transfer coefficient. By allowing the heat transfer coefficient to be a function of the properties of the atmosphere and of the aircraft, no fundamental heating law is invoked by this procedure. If reasonable accuracy is to be attained, however, account must be taken of the fact that both the heat transfer coefficient and the temperature difference are functions of structural surface temperature.

The basic data for laboratory representation of the kinetic heating of an aircraft structure are the aerodynamic parameters, which are determined experimentally in wind tunnels and in flight, and the radiation from the structural surface. These data are transformed into heating rates and heat is applied to the structure in an appropriate manner. In the installation that is to be described, electricity is the source of energy and radiant heat is generated by tungsten filaments in quartz tubes. Provided the convection losses are small the heaters can be packed sufficiently closely to heat a specially blackened surface at the rate of 100 kW/sq ft. The tungsten filament achieves a temperature of about 3000°C at maximum power and the surface temperature of the aircraft does not materially influence the heat absorption for any temperature up to 1000°C; for many installations it is not practicable to operate the filaments at maximum power.

In order to give an indication of the flight conditions that can be reproduced in the laboratory, the initial maximum heating rate and the ultimate temperature of a typical surface are shown in Figs. 1 and 2. The lowest curve of Fig. 1 corresponds to a heating rate of 100 kW/sq ft and the lowest curve of Fig. 2 corresponds to a surface temperature of 1000°C.

The kinetic heating of any point of the surface of the vehicle at any moment is the algebraic sum of the aerodynamic heating and the surface radiation and is given by

$$q_a = h_A (T_A - T_S) - h_{R1} \cdot T_S^4 \quad (1)$$

where  $q_a$  = the heating rate in flight

$T_A$  = the representative temperature of the air in the boundary layer of the aircraft

$T_S$  = the temperature of the surface of the structure

$h_A$  = the heat transfer coefficient in flight

$h_{R1}$  = the radiation constant of the aircraft surface

When this heat is to be reproduced in the laboratory the quantity of heat that has to be produced at the surface is the sum of the heat of equation (1) and the heat required to overcome the total losses from the surface at that part of the structure. The losses are given by

$$q_{\ell} = h_L (T_S - T_L) + h_{R2} T_S^4 \quad (2)$$

where  $q_{\ell}$  = the heating rate required to overcome laboratory losses

$T_L$  = the representative temperature of the air surrounding the test structure

$h_L$  = the convective heat transfer coefficient to the test structure

$h_{R2}$  = the radiation constant of the surface as used in the test specimen.

Thus the total heat that needs to be produced at the surface is

$$q = q_a + q_{\ell}.$$

Hence

$$\begin{aligned} q &= h_A T_A - (h_A - h_L) T_S - h_L T_L + (h_{R2} - h_{R1}) T_S^4 \\ &= h_A T_A - h_S T_S - h_L T_L + h_R T_S^4 \end{aligned} \quad (3)$$

where  $q$  = the net heating rate to be supplied at the surface of the specimen

$$h_S = h_A - h_L$$

$$h_R = h_{R2} - h_{R1}.$$

The control system that has been developed attempts to control the heat entering the surface in accordance with equation (1). The actual computation that has to be made is dependent on the method of measuring the heat flow. Any practical instrument will measure neither the heat flow into the structure, nor the heat produced at the surface of the structure and the instrument reading has to be corrected to one or other of the quantities of heat given by equations (1) and (3), or some combination of them. This affects the number of terms in the equation but, apart from ensuring that the maximum number of terms can be accommodated, it does not affect the control system.

## 2.1 Digital procedure

The main characteristics of the control equipment are that it is entirely in digital form and that the rate of change of heating is proportional to the output from the computer. The first step in this procedure is to split up the whole of the structural surface into a number of areas and control the heat into each area separately. The aim of the system is to represent the continuous function of heating using calculations at discrete time intervals. The heat requirement is estimated at one second intervals and the aim is that the heat supplied is changed linearly during each interval of one second. Thus heat supplied by the system to each area can be plotted against time as a series of straight lines each with a time duration of 1 second. The inaccuracy of this operation is the discrepancy between the laboratory curve of heating and the true curve, it being permissible to move the laboratory curve bodily along the axis. A displacement of 1 second gives a good fit.

The digital procedure of control is given in Fig.3. The aerodynamic data appropriate to the flight conditions and to the laboratory losses are pre-calculated and recorded as binary numbers on film. The film is then read on a time sharing basis for 30 channels and the data from each channel passed to a digital computer once per second. At the same time the computer also receives through a digitiser the surface temperature and the quantity of heat. The structural areas are arranged in pairs to give 60 controlled areas labelled 1A, 1B, 2A, 2B .....30A, 30B for the 30 sets of aerodynamic data, and normally each pair consists of corresponding areas on the port and starboard sides. The heat that is supplied to each area is controlled by a power regulator. The power regulator receives the answer to the calculation made by the computer once per second. This answer is the adjustment of power to the heaters that has to be made during the following second. The power regulator changes the power linearly with time during that second. At the end of the second it receives the answer to the next calculation and the whole procedure is repeated at one second intervals for the duration of the test. It should be noted that the difference between the measured heat and the calculated heat is not an indication of the error as most of this difference merely represents a time delay of about 1 second in doing the experiment.

### 3 METHODS OF DIGITISING

#### 3.1 Surface areas

The whole surface area has to be divided up into discrete parts, within each of which are reasonably uniform aerodynamic and structural characteristics. The aerodynamic properties vary in a fairly gradual manner, except at the leading edge of the aerofoil sections and at the transition from laminar to turbulent flow. Provided special care is taken in these regions considerable latitude can be taken in choice of boundaries to satisfy the aerodynamic conditions. The structural characteristics may change more abruptly than the aerodynamics and it is particularly important that lines where the outer skin has a change of thickness are boundaries of the control areas. Major concentrations of internal thermal mass such as fuel tanks also cause fairly abrupt changes of surface temperature.

In a practical application it is possible to have different spacing of heaters within an area to produce non-uniform heating, but this is unlikely to be of much advantage as the required distribution of heating changes with the surface temperature. An exception to this can occur near the extremities of the structure where heat may be lost to the test frame.

#### 3.2 Pre-calculated data

The representative aerodynamic temperature and heat transfer coefficients are pre-calculated for the particular flight condition that is being reproduced. As the heat transfer coefficients in flight and in the laboratory depend on the surface temperature, an assumed change of surface temperature with time has to be used. The dependence on surface temperature is not critical and even in extreme cases it would only be necessary to do one preliminary test to estimate the surface temperature with sufficient accuracy for the determination of the heat transfer coefficients.

These data are each recorded as 8 digit binary numbers on 16 mm film. Each frame of the film is divided up into 34 rectangles that can be exposed separately. Two of the rectangles are used to identify the position of the data on the film, 16 of the rectangles are used to record the two 8 digit aerodynamic properties and the remaining 16 are available for other data, in particular to record the parameters determining the convective losses in the laboratory. Thirty successive frames on the film represent aerodynamic data for 30 pairs of separately controlled areas.

### 3.3 Measured data

It has been shown that the control procedure necessitates the calculation of the change of heat required during each second. This is a function of the pre-calculated aerodynamic properties, the heat input into the outer surface of the structure and the temperature of that surface. The surface temperature and the heat that is being supplied have to be measured and digitised during the test.

Thermocouples are used to measure both these properties. The measurement of rate of heating is reduced to the measurement of the temperature difference between the centre and perimeter of a thin circular disc of 3 mm diameter, the perimeter being in good thermal contact with a large thermal mass; the instrument is called a "radiometer". If the disc has the same radiation constant  $h_{R2}$  as the surface of the test specimen it will receive the same rate of radiation heating as the test specimen. It has been shown experimentally for normal types of oven and the particular radiometers (which have no specially designed aerodynamic features) that the heat transfer coefficient is the same for the specimen and for the disc. If the disc has an effective temperature of  $T_R$  it will have heat losses of

$$h_L (T_R - T_L) + h_{R2} T_R^4 \quad (4)$$

Thus the apparent rate of heating ( $q_m$ ) deduced from the temperature difference between the centre and the perimeter<sup>m</sup> of the disc will be  $q$  minus these losses. This reduces to

$$q_m = h_A T_A - h_S T_S - h_L T_R + h_R T_S^4 - h_{R2} T_R^4 \quad (5)$$

If  $T_R = T_S$  equation (5) reduces to equation (1).

In both cases the digitising procedure is one of measuring a voltage of digits. The actual digitiser is designed to have 180 channels arranged in groups of three, one for surface temperature, one for heating rate and one being available for other data such as the fourth power of the surface temperature. The time cycle is 1 second thus allowing 1/60 second for each group of three measurements. Considerable error would be introduced if an attempt were made to read the voltage of the thermocouples (i.e. about 0.01 volts) in such a short time, as spurious signals at the fundamental and the harmonics of the mains electrical power frequency are unavoidable. Each thermocouple voltage is passed through an amplifier, which also acts as a filter, and the amplifier voltage is digitised. Each amplifier responds well to frequencies up to 10 cycles per second and has a low response to all above 20 cycles per second. On being connected to a thermocouple the output of the amplifier takes about 1/10 second to settle down and thereafter follows the thermocouple voltage with a time delay of about 1/10 second. Thus provided the amplifier has been connected for 1/10 second before a reading is taken, no greater accuracy can be achieved by maintaining the connection longer. Advantage is taken of this in the design by using each amplifier on a time sharing basis for 10 thermocouples.

The digital readings for each group of 3 temperatures are required by the digital computer at the same time and the simultaneous digitising is done on three digitisers. Each digitiser is capable of digitising a 10 binary digit number 500 times per second but this does not include the time taken for the input and output of the information. In the present installation it is possible to feed the information in and out on 60 channels and complete a cycle in 1 second.



### 3.4 Power

The calculation of heat is done on a digital computer and the answer from the computer is the calculated value of the rate of heating to be supplied at the end of each second less the measured value at the beginning and is in digital form. The power delivered by the power regulators is changed during each second by an amount corresponding to this change in heating rate.

The power regulators are multi-tap transformers with the spacing of the tappings approximately equal for equal steps in power with the standard heaters. The contact arm to the taps is driven by means of a D.C. electric motor so that a constant speed of the motor corresponds closely to a constant rate of change of power absorbed by the heaters. The power output can change from zero to full power in approximately 5 seconds.

The output from the computer is a number from 0 to 63 that is changed once per second. It is stored on relays and used to control the speed of the D.C. motor. The motor has a fixed field current and the voltage to the armature can be at any one of 32 positive or 32 negative levels adjacent levels being 7 volts apart except between levels corresponding to numbers 31 and 32 which are 63 volts apart, i.e. Number 31 and 32 are at  $\pm 31\frac{1}{2}$  volts. It has been shown experimentally that 28 volts are required to overcome starting resistance and that the speed at all other voltages is proportional to the actual voltage less 28 volts. Thus, the digital readings from the computer are converted to rates of change of heat flow into the structure as given below.

Computer output No.	0	1	2	...	30	31	32	33	...	61	62	63	
Rate of change of heating		$-31\frac{1}{2}$	$-30\frac{1}{2}$	$-29\frac{1}{2}$	...	$-1\frac{1}{2}$	$-\frac{1}{2}$	$+\frac{1}{2}$	$+1\frac{1}{2}$	...	$+29\frac{1}{2}$	$+30\frac{1}{2}$	$+31\frac{1}{2}$

In this way the D.C. motor will always be moving and static friction errors eliminated. In conditions of near equality of measured and calculated power, the motor will change the lamp output by + or  $-\frac{1}{2}$  unit of power in one second. This change in power is about  $\frac{1}{2}\%$  of full power.

### 3.5 Time

The time scale is digitised and synchronisation provided at the reader of the film of pre-calculated (e.g. aerodynamic) data. The timing element of the reader consists of a motor-driven multi-point selector switch, which sweeps through 30 contacts per second. Thus each operation takes about 33 milliseconds, and of this time 13 milliseconds are required for the actual movement between contacts, the remaining period being available for computation and control. Synchronisation is achieved by having on the same shaft the reading head for the aerodynamic data, the switches feeding amplified analogue voltages to the digitisers for surface temperature and heating rate, and the switches feeding the digitised output from the digital computer to the appropriate power regulator. Synchronising contacts on this shaft also control remote selector switches switching appropriate thermocouples to the amplifiers at a rate of 10 per second.

## 4. CONTROL SYSTEM

### 4.1 Digital computer

The central position of the whole control system is occupied by the digital computer. This is a special computer that solves one group of equations only. In view of the time taken to develop the computer, a decision had to be

taken early as to the form of the equations to be used. All the other parts of the system have to be matched to the computer. A compromise has to be made between extreme elaboration of the equations and consequential complexity of the digital computer, on the one hand, and simplicity of the equations with limited scope for further development, on the other.

The equation that can be solved by the computer is of the form

$$E = \pm a_1 X_1 \pm a_2 X_2 \pm a_3 X_3 \pm a_4 X_4 \pm a_5 X_5 \quad (6)$$

where all the a's and X's are positive 8 digit binary numbers. Normally it would be expected that the a's are pre-calculated values and the X's measured values. E is in the form of positive numbers or the negative complement. This equation has to represent the difference between the calculated and measured rate of heating. This takes its simplest form when the calculated heat is given by equation (1) and the radiation in the laboratory is equal to that in flight and in addition the radiometer measuring the heat flow has the same radiation. The equation then to be solved is

$$E = h_A T_A - h_A T_S - q_m \quad (7)$$

and there are two out of the five channels of the computer out of use.

If the calculated heat is given by equation (3) all the channels are in use and

$$E = h_A T_A - h_S T_S - h_L T_L + h_R T_S^4 - q_m \quad (8)$$

In this case there is a further complexity due to the term  $T_S^4$ . The computer was designed not to be able to multiply more than two numbers in any one channel and a separate multiplier or converter is needed to transform  $T_S$  into  $T_S^4$  before passing it to the computer.

#### 4.2 Time sharing

The time taken for the actual computation is less than a millisecond and the main portion of the time per control channel is devoted to input and output from the computer. Fig.4 gives the time sharing of the whole control system and includes the allocation of time to the computation for a pair of control channels. Each pair of channels uses one way on a 30 way selector switch. It will be seen that the two computations take approximately 20 milliseconds and that 13 milliseconds are required for moving from one contact to the next. This 13 milliseconds might be regarded as wasted time and improved switching could increase the number of computations per second. With regard to the 20 milliseconds for each pair of computations, it would be necessary to use electronic gates instead of relay contacts for switching if this time had to be reduced. All the steps in this operation must be done in sequence and some part of the computer is being used for the whole of this period. A cursory examination would indicate that the digitisers are working for too small a fraction of the total time, but if the three digitisers were replaced by one there would be an increase of at least 8 milliseconds on the 20 milliseconds for each pair of computations. The waste of the computer's time would be far more costly than the saving in the cost of two digitisers quite apart from the extra switching complexity.

#### 4.3 Accuracy of a 1 second time cycle

In the procedure that is being adopted the aim is for the power regulators to produce a constant rate of change of power between computer calculations that are made once per second. In order to see the extent to which the system can be used an estimate must be made of the errors that might be introduced by working to a time cycle of 1 second. The error will depend on the variation of heating rate with time and also on the thermal mass of the structure and particularly that of the outer shell. For any practical condition the error should be less than that for an instantaneous change of heat transfer coefficient and aerodynamic temperature. Fig.5 gives an estimate of the error that would be produced on heating rate and in surface temperature in this extreme case. In making the comparison it has been assumed that as far as the test is concerned, zero time is at the moment when the first calculation is made, but that the first aerodynamic conditions refer to a time of 1 second having elapsed. It is also assumed that the heaters are switched on at the correct heating rate to avoid a mathematic discontinuity. It can be seen from the diagram that the test heating and the test surface temperatures are higher than they should be for the whole duration of the test, the error increasing to a maximum and then reducing asymptotically to zero. The maximum error in temperature is  $0.367 \delta t/MR$

where  $\delta t$  is the time interval between calculations

$M$  = thermal mass of the shell per unit area

$R$  = effective thermal resistance to heat flow per unit area

it can be shown that -

$R \doteq$  thermal resistance of air plus  $1/3$  thermal resistance of shell per unit area.

This error can be kept less than 1% by keeping  $\delta t/MR$  less than  $1/36.7$ , so that for a 1 second time interval  $MR$  has to be greater than 36.7. This corresponds to an aluminium skin of about 0.015 in. thick in the surface of a vehicle flying at 100,000 ft, 0.15 in. at 50,000 ft and 1 in. at ground level. The corresponding values for steel are about half the thickness. It is only in very rare cases that the control system operating on a one second time cycle would be too slow. If it were intended to use a shorter interval than 1 second, considerable attention would have to be paid to the remainder of the system as it would be very difficult to ensure sufficiently rapid response of the whole of the practical installation including the radiometers, heaters and power regulators, to take advantage of the greater frequency of making calculations.

With the time cycle as described the error to surface temperature due to the time cycle will make the test slightly too severe but will only be as much as 1% on very rare occasions. There are, of course, all the normal experimental inaccuracies in the remainder of the system.

#### 5 THE COMPLETE APPARATUS

The components of the actual apparatus, whose characteristics have been described, have been developed either at the R.A.E. under the general direction of Mr. J.R. Sturgeon or at industrial firms to R.A.E. requirements; the apparatus is shown in Figs.6-10. It has power regulators with a continuous rating of 50 kW and a rating for 20 minutes of 100 kW. At present there are 30 regulators giving a total capacity of 3000 kW but if the installation were to be increased to the full number of 60 regulators that the digital computer can operate, it is intended that the other 30 regulators should each have

200 kW capacity, thus bringing the total to 9000 kW. Fig.6 shows the film, on which the pre-calculated data is recorded, being passed through the film reader. Fig.7 gives a general view of the control room. Fig.8 shows two cabinets each containing 3 power regulators installed in the power house; Fig.9 shows a close-up of a power regulator with its D.C. motor for the change of power level. Fig.10 shows a typical test on a cylinder, the reflectors having been removed to show the heaters.

One of the major problems in equipment of this nature is reliability. Individual prototype power controllers can readily be made serviceable and checked but a special system of checking is essential when the number is increased to 60. A simple check is maintained during a test on a series of voltmeters and ammeters in the control room. A monitor channel is a vital part of the control and one of the 60 control channels is used to heat a dummy specimen on which measured temperatures can be compared with correct values. For many of the early tests the 60 spare measuring channels will be used for recording temperatures and heating rates at selected points during the tests. In addition a continuous record is taken of the heating rates and displayed whilst the test is in progress.

---

LIST OF SYMBOLS

- $q_a$  = the heating rate in flight
- $q_\ell$  = the heating rate required to overcome laboratory losses
- $q$  = the net heating rate to be supplied at the surface of the specimen
- $q_m$  = the heating rate measured by a radiometer
- $T_A$  = the representative temperature of the air in the boundary layer of the aircraft
- $T_R$  = effective temperature of radiometer disc
- $T_S$  = the temperature of the surface of the structure
- $T_L$  = the representative temperature of the air surrounding the test structure
- $h_A$  = the heat transfer coefficient in flight
- $h_L$  = the convective heat transfer coefficient to the test structure
- $h_S$  =  $h_A - h_L$
- $h_{R1}$  = the radiation constant of the aircraft surface
- $h_{R2}$  = the radiation constant of the surface as used in the test specimen
- $h_R$  =  $h_{R2} - h_{R1}$
- $M$  = thermal mass of the shell per unit area
- $R$  = effective thermal resistance to heat flow per unit area
- $\delta t$  = time interval between calculations for each area

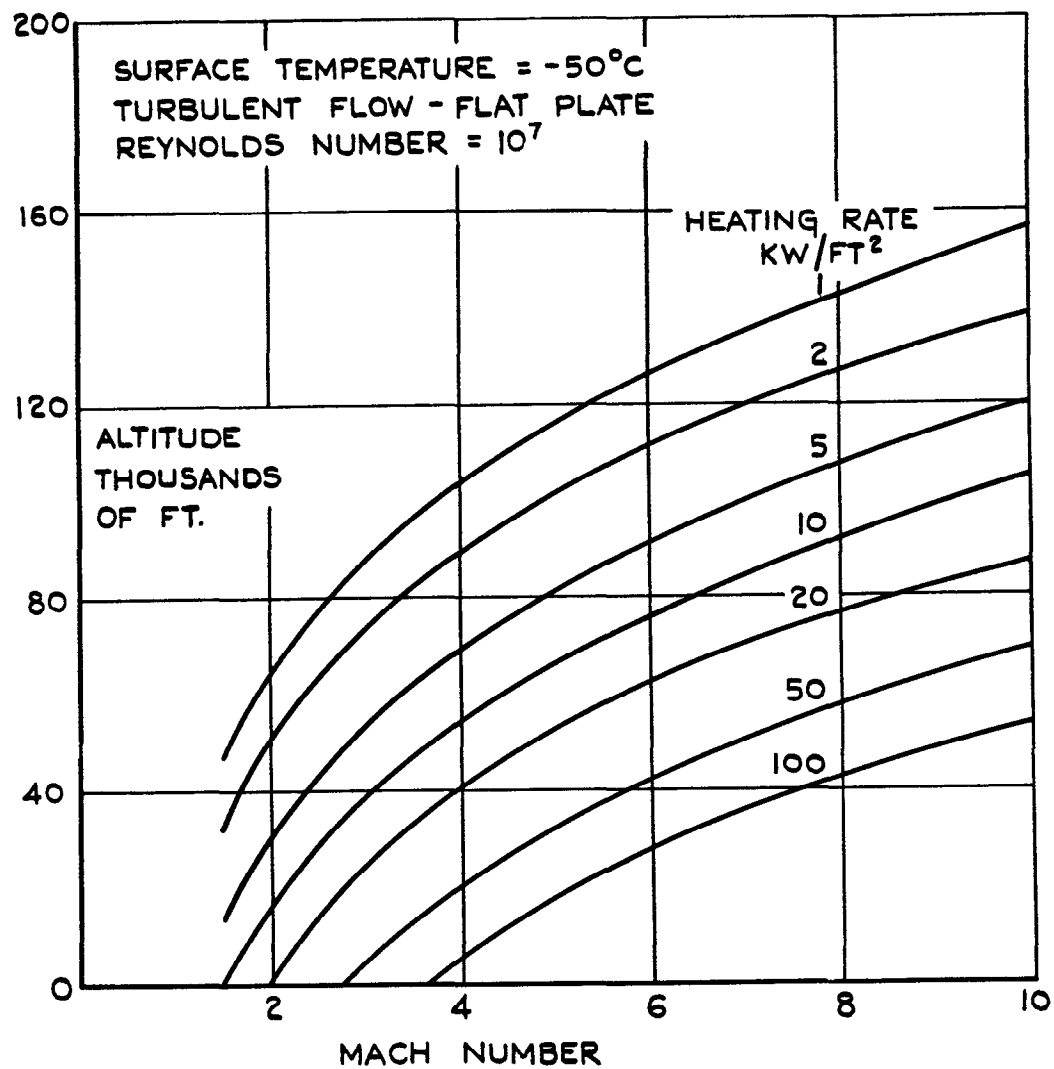

FIG. 1. INITIAL HEATING RATE.

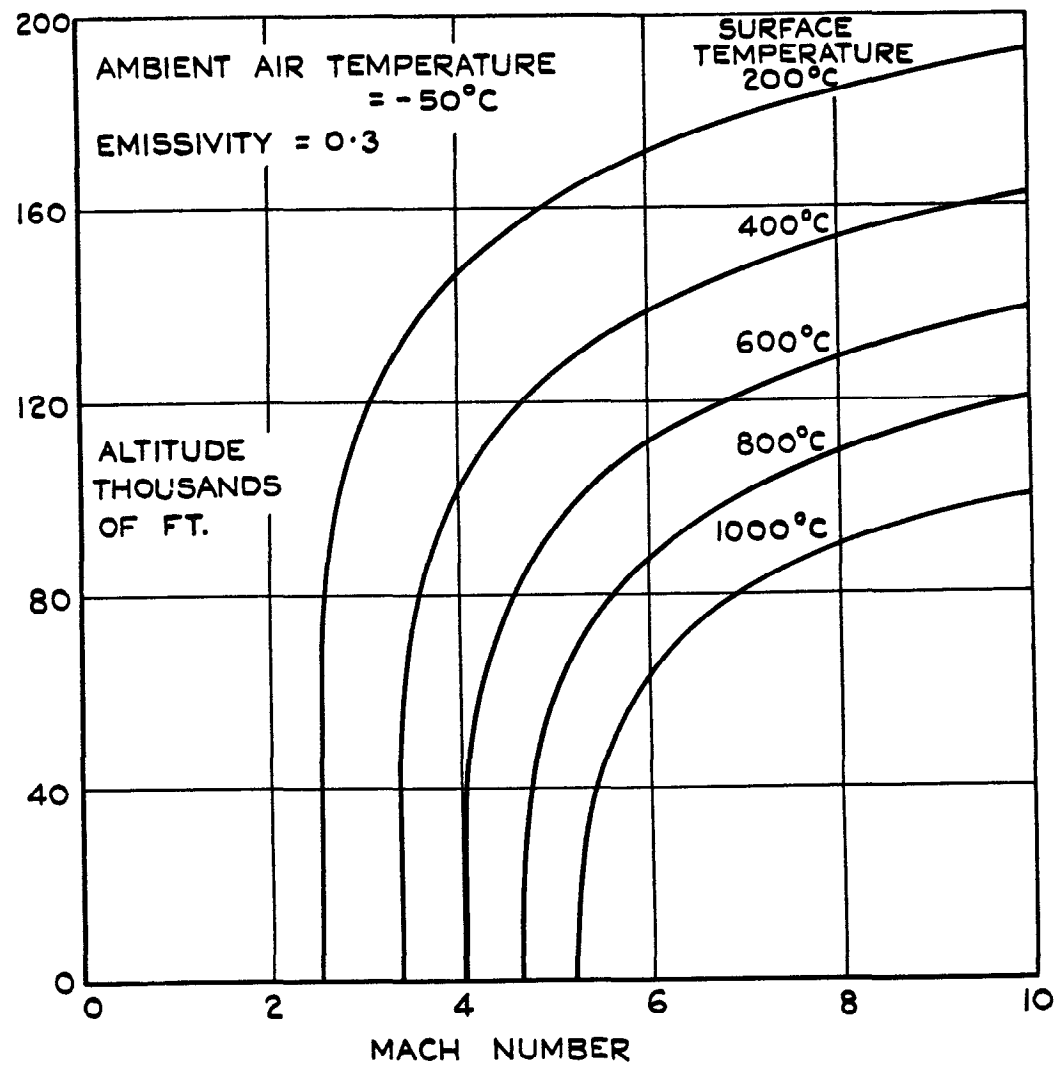

FIG. 2. ULTIMATE EQUILIBRIUM TEMPERATURE.

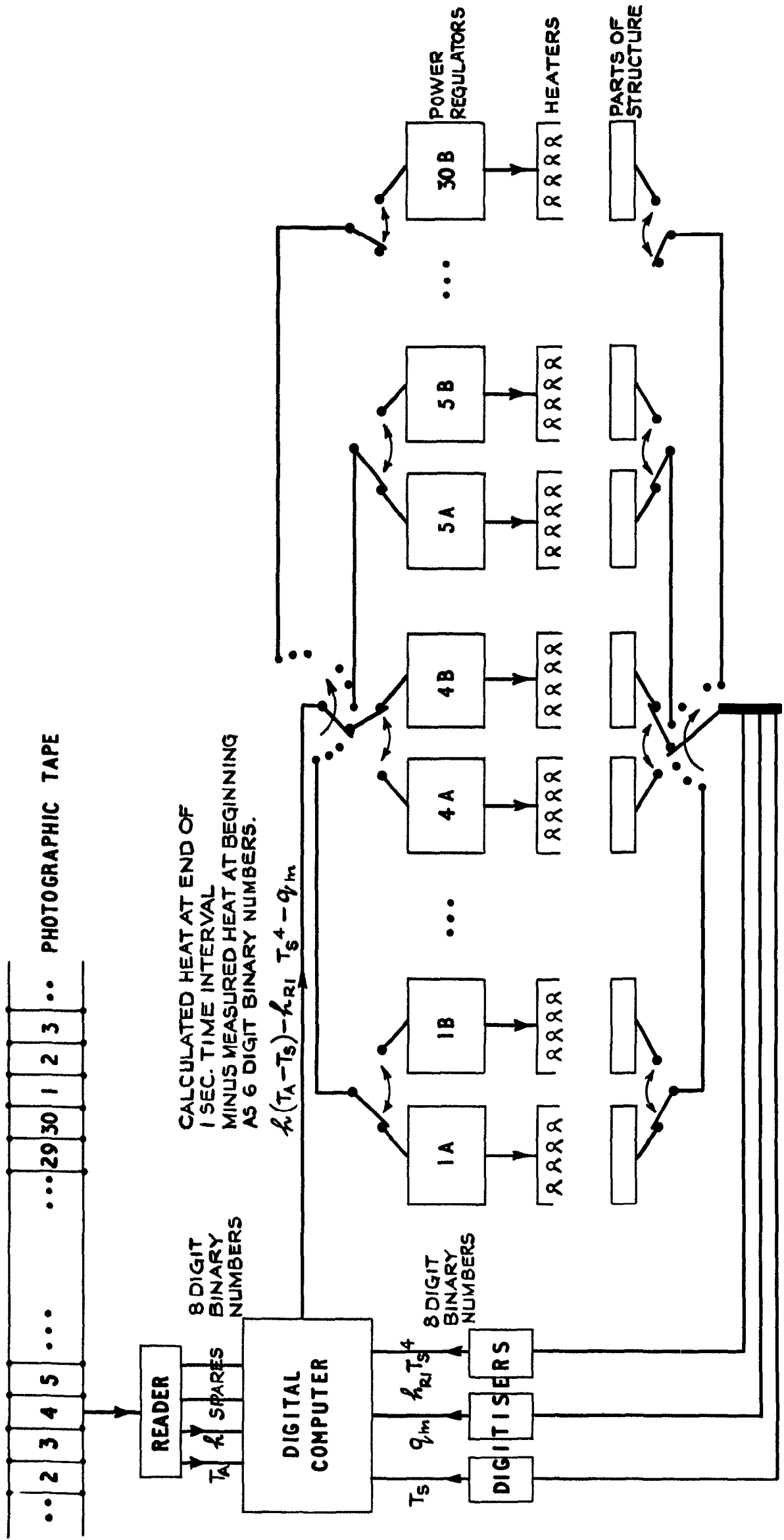
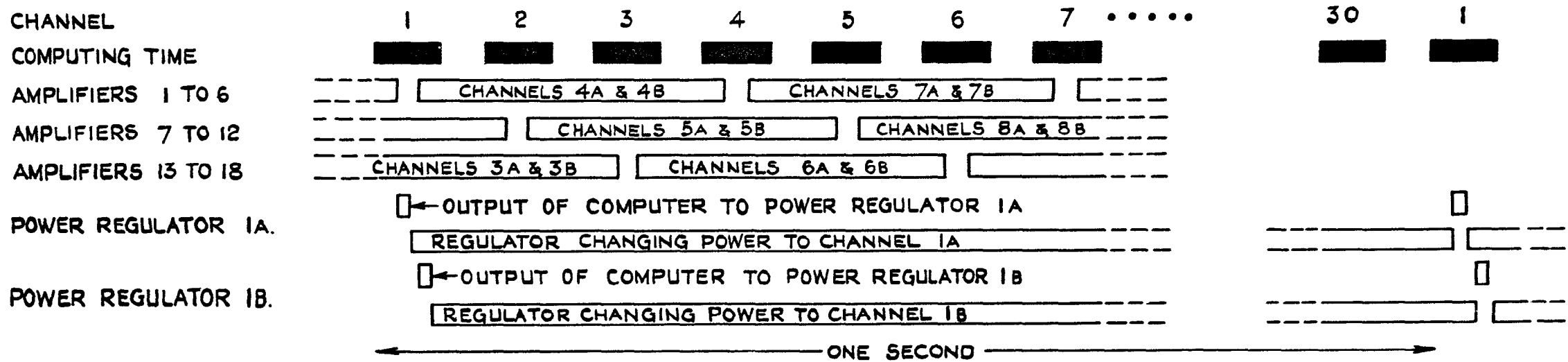
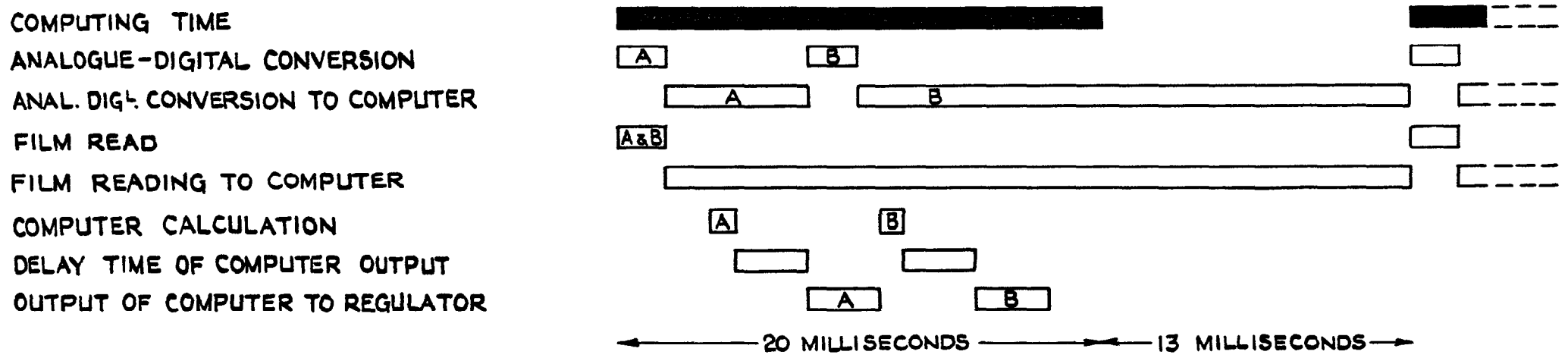

FIG. 3. DIGITAL PROCEDURE OF CONTROL IN EXAMPLE SELECTED FOR ILLUSTRATION THE MEASURED QUANTITY OF HEAT IS THAT ENTERING THE STRUCTURE



(a) AMPLIFIERS AND REGULATORS



(b) COMPUTER

FIG.4.(a & b) TIME SHARING OF THE CONTROL SYSTEM

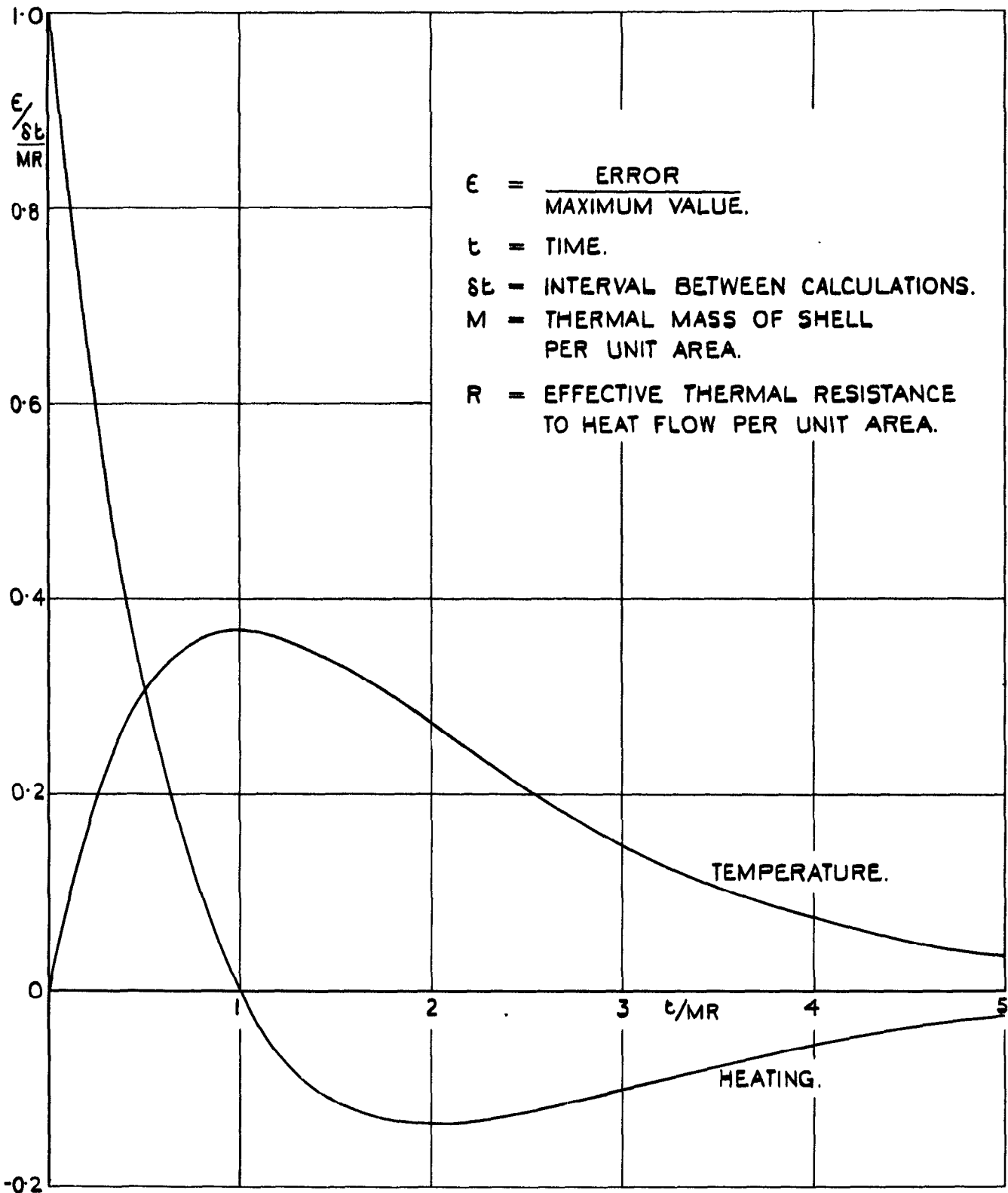

**FIG. 5. ERROR IN HEATING AND SURFACE TEMPERATURE OF SHELL.**

SHELL SUDDENLY EXPOSED TO A CHANGE OF AERODYNAMIC TEMPERATURE.

RATE OF CHANGE OF HEATING CALCULATED AT A TIME INTERVAL OF  $st$ .



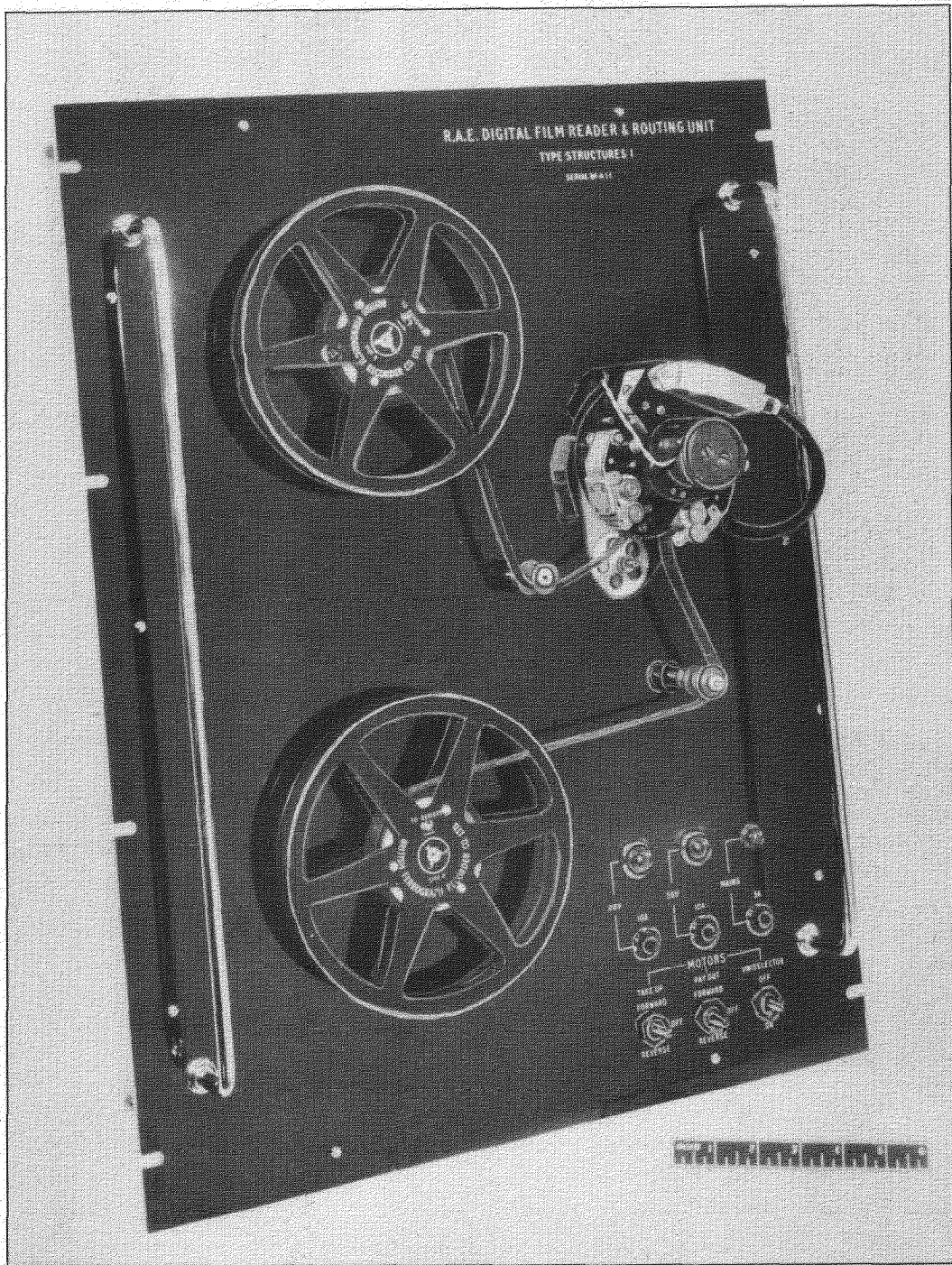

FIG. 6. FILM READER FOR PRE-CALCULATED DATA

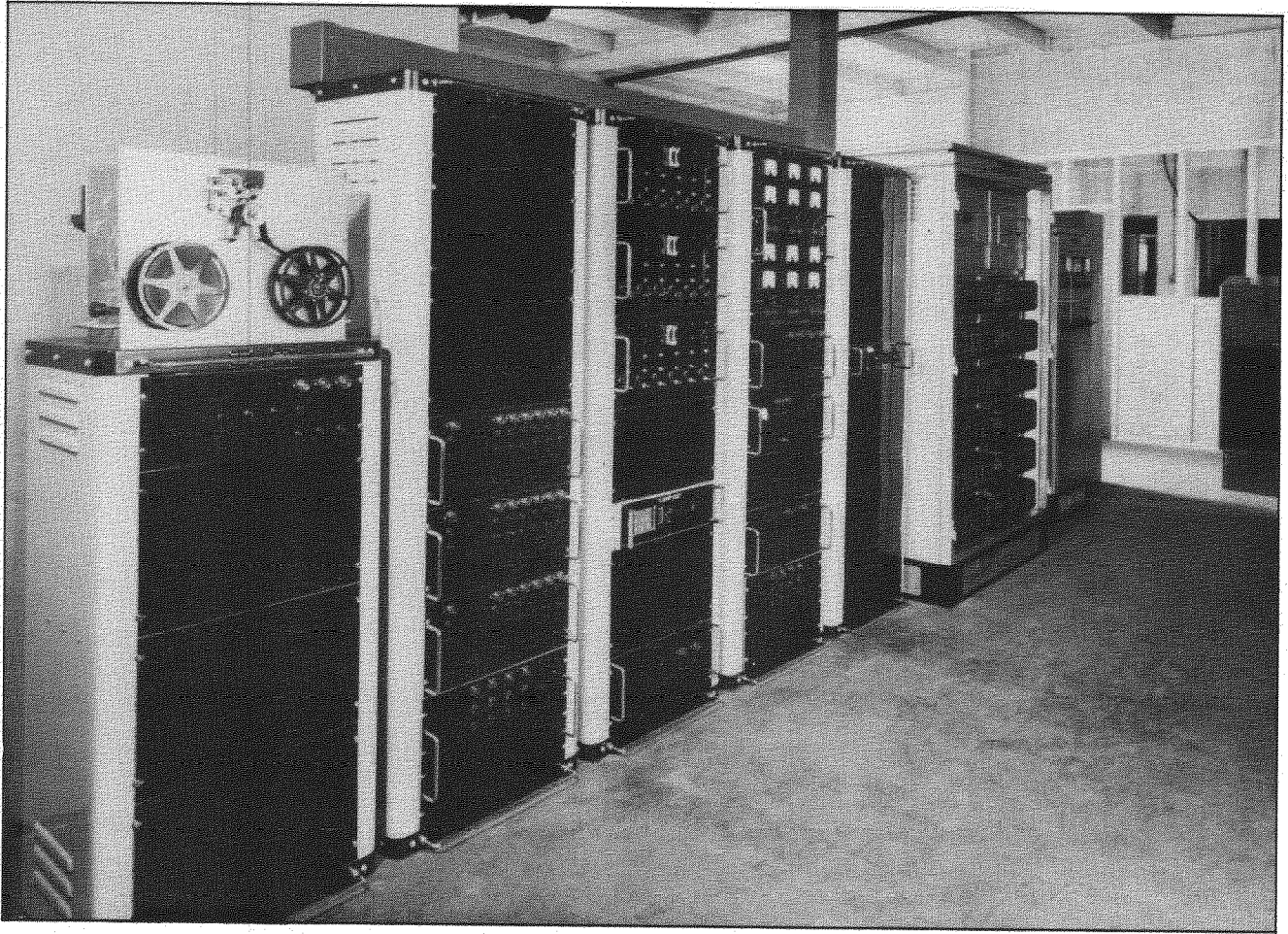
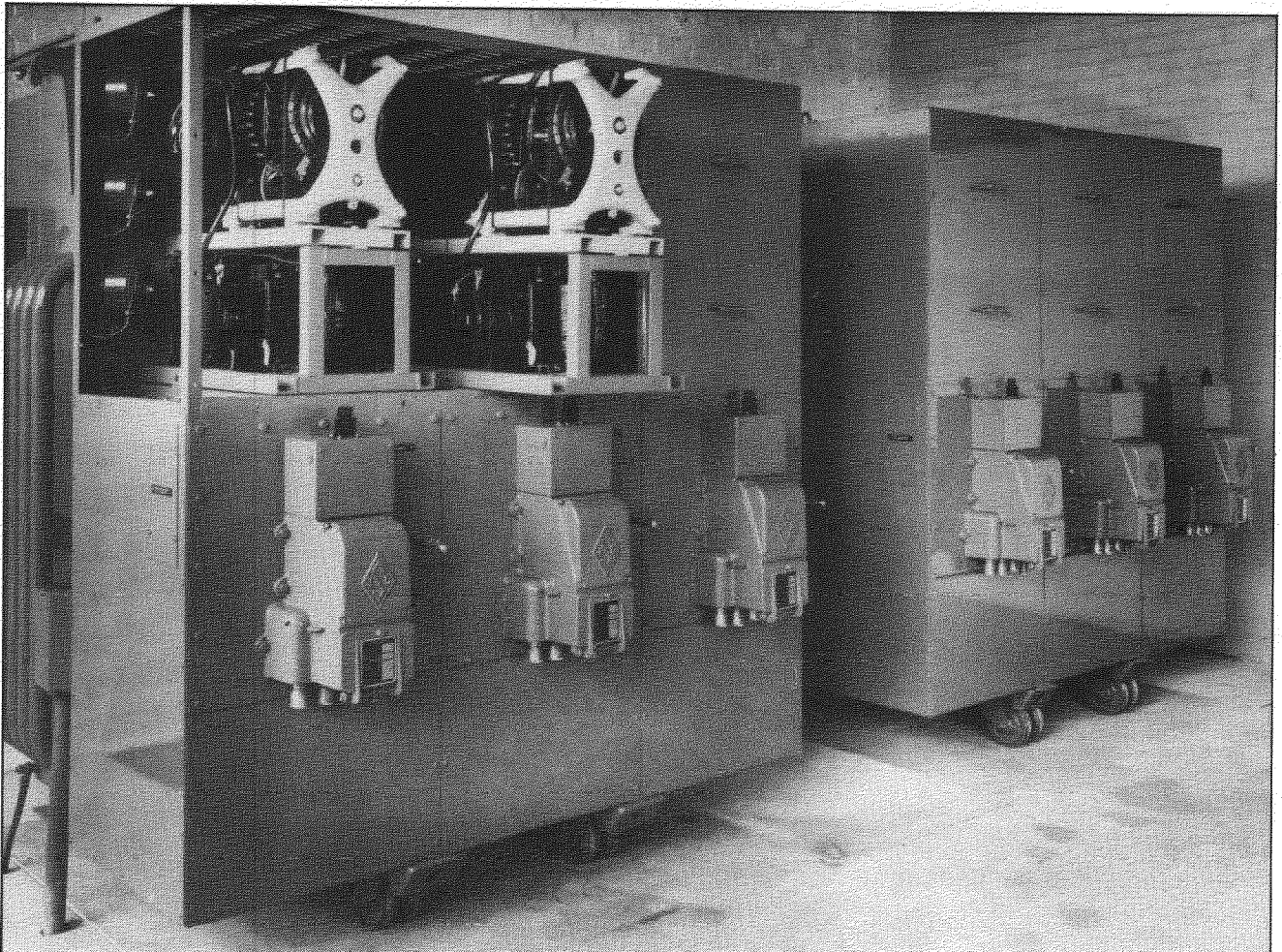

FIG. 7. CONTROL ROOM



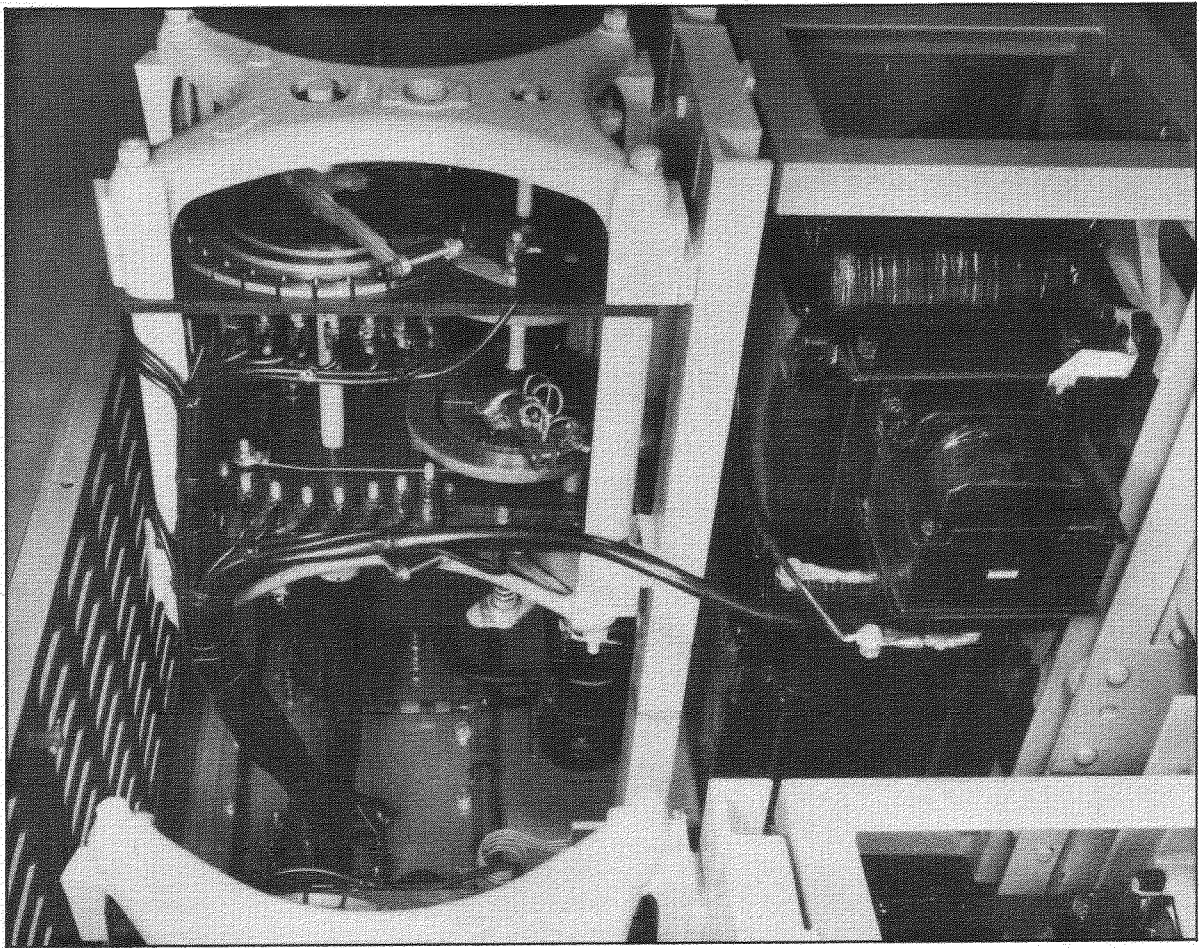

FIG. 9. CLOSE-UP OF POWER REGULATOR

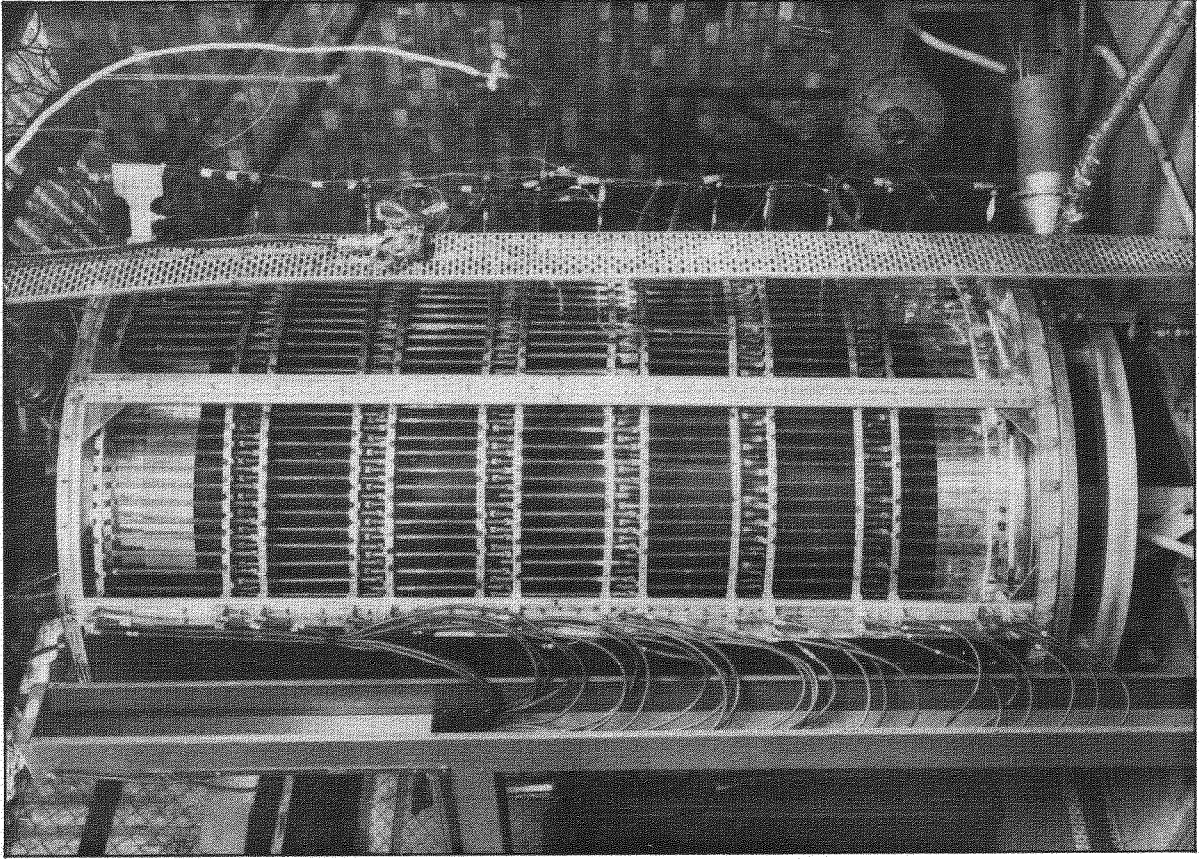

FIG. 10. HEATING TEST ON CYLINDER, WITH HEATER REFLECTORS REMOVED

C.P. No.532

533.6.011.6 :  
621-52

AUTOMATIC CONTROL OF LABORATORY REPRESENTATION OF KINETIC HEATING.  
Taylor, J. July, 1960.

The purpose of the control system is to heat an aircraft structure by electrical power in the laboratory in a manner representative of the heating it receives in flight from its motion through the air.

The main characteristic of the control equipment is that it is entirely in digital form. The structural surface is divided into a number of discrete areas and each area is controlled separately. The basic aerodynamic data is presented in digital form at discrete time intervals to a computer. The computer also receives in digits the measured temperature of representative points of the structural surface

C.P. No.532

533.6.011.6 :  
621-52

AUTOMATIC CONTROL OF LABORATORY REPRESENTATION OF KINETIC HEATING.  
Taylor, J. July, 1960.

The purpose of the control system is to heat an aircraft structure by electrical power in the laboratory in a manner representative of the heating it receives in flight from its motion through the air.

The main characteristic of the control equipment is that it is entirely in digital form. The structural surface is divided into a number of discrete areas and each area is controlled separately. The basic aerodynamic data is presented in digital form at discrete time intervals to a computer. The computer also receives in digits the measured temperature of representative points of the structural surface

C.P. No.532

533.6.011.6 :  
621-52

AUTOMATIC CONTROL OF LABORATORY REPRESENTATION OF KINETIC HEATING.  
Taylor, J. July, 1960.

The purpose of the control system is to heat an aircraft structure by electrical power in the laboratory in a manner representative of the heating it receives in flight from its motion through the air.

The main characteristic of the control equipment is that it is entirely in digital form. The structural surface is divided into a number of discrete areas and each area is controlled separately. The basic aerodynamic data is presented in digital form at discrete time intervals to a computer. The computer also receives in digits the measured temperature of representative points of the structural surface

C.P. No.532

533.6.011.6 :  
621-52

AUTOMATIC CONTROL OF LABORATORY REPRESENTATION OF KINETIC HEATING.  
Taylor, J. July, 1960.

The purpose of the control system is to heat an aircraft structure by electrical power in the laboratory in a manner representative of the heating it receives in flight from its motion through the air.

The main characteristic of the control equipment is that it is entirely in digital form. The structural surface is divided into a number of discrete areas and each area is controlled separately. The basic aerodynamic data is presented in digital form at discrete time intervals to a computer. The computer also receives in digits the measured temperature of representative points of the structural surface

and of the laboratory. The computer calculates the required quantity of heat and subtracts from it the measured heat being supplied at that moment. This figure is passed to a controller, which then ensures that the heating elements just achieve the new electrical power level in the prescribed unit of time. The whole process is then repeated continuously.

Since the time required by the digital computer to make its calculations is small compared with a unit time interval, the computer and many of the digitising processes are used on a time-sharing basis for up to 60 separate controllers.

and of the laboratory. The computer calculates the required quantity of heat and subtracts from it the measured heat being supplied at that moment. This figure is passed to a controller, which then ensures that the heating elements just achieve the new electrical power level in the prescribed unit of time. The whole process is then repeated continuously.

Since the time required by the digital computer to make its calculations is small compared with a unit time interval, the computer and many of the digitising processes are used on a time-sharing basis for up to 60 separate controllers.

and of the laboratory. The computer calculates the required quantity of heat and subtracts from it the measured heat being supplied at that moment. This figure is passed to a controller, which then ensures that the heating elements just achieve the new electrical power level in the prescribed unit of time. The whole process is then repeated continuously.

Since the time required by the digital computer to make its calculations is small compared with a unit time interval, the computer and many of the digitising processes are used on a time-sharing basis for up to 60 separate controllers.

and of the laboratory. The computer calculates the required quantity of heat and subtracts from it the measured heat being supplied at that moment. This figure is passed to a controller, which then ensures that the heating elements just achieve the new electrical power level in the prescribed unit of time. The whole process is then repeated continuously.

Since the time required by the digital computer to make its calculations is small compared with a unit time interval, the computer and many of the digitising processes are used on a time-sharing basis for up to 60 separate controllers.



© *Crown Copyright 1961*

Published by  
HER MAJESTY'S STATIONERY OFFICE

To be purchased from  
York House, Kingsway, London w.c.2  
423 Oxford Street, London w.1  
13A Castle Street, Edinburgh 2  
109 St. Mary Street, Cardiff  
39 King Street, Manchester 2  
50 Fairfax Street, Bristol 1  
2 Edmund Street, Birmingham 3  
80 Chichester Street, Belfast 1  
or through any bookseller

*Printed in England*